

Hijacked Predicate Raising in an AAE Attributive

Construction*

Patricia Irwin

1 Introduction

1.1 The phenomenon

This paper shows how a construction in African American English (AAE) sheds light on two seemingly unrelated topics in linguistic theory: the presence of unpronounced nominals and the nature of attributive modification. Colloquial AAE and other varieties of English have a construction that has been noted by Spears (1998) and Collins, Moody & Postal (2008) (henceforth *CMP*), and exemplified in (1):

- (1) Gwen's dumb ass husband forgot the beer. (CMP, 9)

This construction consists minimally of two parts: an adjective (e.g., *dumb*, *crazy*) or a noun (e.g., *fool*, *punk*) and the word *ass*; these two parts together serve to modify a noun, as shown in (1), where *dumb ass* modifies *husband*. Because of the attributive modificational nature of this construction, I will call it the *Ass Attributive Construction* (AAC). Because the construction admits some alternatives to the word *ass* (e.g., *behind*, *butt*), as I will discuss further below, I will refer to this component of the construction as the *a-word*. My analysis of this construction involves a combination of the raising of a predicate and movement into the extended projection of an a-word (movements which I call *hijacking*), followed by a continuation of predicate raising, this time by the modifier and a-word constituent, into attributive (prenominal) position. This analysis thus relies on a reduced relative clause analysis of attributive adjectives (cf. Smith 1961, Kayne 1994, Alexiadou 2001, Leu 2008) and sideways movement into a camouflage construction (cf. Nunes 1995, Bobaljik and Brown 1997, Nunes 2001, Collins 2007a, Roehrs 2007).

A special case of the AAC consists of a determiner and adjective or noun, plus the a-word, as exemplified in (2).

- (2) Gwen's husband is a dumb ass.

Because this construction can only be used for something that is [+human], I call this construction the [+human] AAC construction. Although the [+human] construction appears to be different from the canonical AAC in that the adjective (e.g., *stupid*) appears to modify the a-word, I will argue that the [+human] AAC involves the presence of an unpronounced but

* I would like to thank Andrea Cattaneo, Chris Collins, Richard Kayne, Tom Leu, Oana Savescu, John Singler, Arthur Spears, and two anonymous reviewers for insightful comments and discussion.

syntactically active nominal PERSON (indicated by small caps). In other words, I analyze (2) as (3).

(3) Gwen's husband is a stupid ass PERSON.

This aspect of the paper therefore contributes to recent cross-linguistic research on syntactically relevant but unpronounced nominals, as discussed by Katz and Postal (1964), Kayne (2005a, 2005b, 2005c), Kester (1996), Cattaneo (2007) and Corver (2007), to name a few.

The structure of the paper is as follows: In the first section, I give an overview of the data, calling attention to what must be accounted for in an analysis of the AAC. In the next section, I give my analysis of the canonical AAC and show how it gives a fuller account of the data as compared to some alternative accounts. In the final section of the paper, I focus on the [+human] AAC and show that it is not a separate construction but one that is derived from the canonical AAC, with the addition of an unpronounced but syntactically active PERSON element.

1.2 Data and informants

The grammaticality judgments in this paper all come from informants who identify as African-American and native speakers of AAE. Because of my hunch that the AAC and another construction, the “*ass* Camouflage Construction (ACC)” (CMP, 2), are related, I chose only informants who accepted sentences with the ACC. I worked primarily with three informants: a 28 year old male, a 44 year old male, and a 50 year old female. All informants were life-long residents of the tri-state (New York City) area. The 28 year old informant had spent 5 years outside the tri-state area, in Raleigh, North Carolina. In order to minimize the influence of Caribbean dialects or other languages and dialects that are spoken primarily outside the U.S., only informants whose parents were born and raised in the U.S. were used (this may be a challenge particular to work on AAE in the northeastern states). The majority of the judgments in this paper come from the two male informants; the female informant dropped out part-way through informant work because she didn't like giving judgments what she considered to be incorrect (i.e., non-standard) English, and she wasn't comfortable with the swear words in the data.

The data come from numerous sources: contrived sentences, examples from CMP and Spears (1998), examples from the internet, from popular media (e.g., films), and examples offered by informants. Because it is difficult to determine whether any given example from the internet is from a speaker of AAE, I did my best to use only examples that were likely to come from AAE speakers (e.g., discussion forums targeted at African-Americans). More importantly, all the examples in this paper, regardless of source, were judged by the informants that I worked with. In other words, although I have cited Web pages for some of the data in this paper, the grammaticality judgments on them come from my informants.

1.3 Background

The construction I discuss in this paper closely resembles the construction analyzed in CMP, the “*ass* Camouflage Construction (ACC)” (CMP, 2), and I argue in this paper that these two constructions, the AAC and the ACC, are related. Because I make comparisons between the two constructions at certain points in this paper, I give a brief overview below of the ACC and CMP's analysis of it.

The ACC is very similar to the AAC at first glance, and although I argue that they have structural similarities, they also have significant differences, noted as far back as Spears (1998,

235).¹ The sentences in (4) compare these two forms. Sentence (4)a shows the AAC, the construction that I analyze, and sentences (4)b and c show the ACC, the construction that CMP analyze.

- (4) a. Gwen's dumb ass husband forgot the beer again. (AAC)
 b. Gwen's dumb ass forgot the beer again. (ACC)
 c. I'm gonna sue her ass. (ACC, CMP's example 1b)

The first broad difference to note is that (4)a and (4)b have different truth conditions: in (4)a, Gwen's husband is the one who forgets the beer; in (4)b, it is Gwen herself who forgets the beer. A second difference is that unlike the AAC, the ACC always involves a possessive structure. Although the AAC example (4)a has a possessive, it does not have to.² This fact is exemplified by (5).

- (5) That dumb ass guy forgot the beer again. (ACC; no possessive required)

In CMP's analysis, the ACC involves a complex possessive structure in which the head NP is, in my terms, an a-word. The a-word determines certain properties of the whole DP, for example, verbal agreement (3rd person). The mandatory possessor in the ACC determines other properties of the whole DP, such as binding and control. CMP's analysis of the ACC is shown in (6).

- (6) $[_{DP1} [_{DP2} \text{Gwen}] [_D' [_D \text{'s}] [_{NP} \text{ass}]]]$

CMP describe the ACC as an instance of grammatical “camouflage,” because the part of this complex DP structure that matters for truth conditions is the possessor (DP2 in (6)), not the head noun (NP) (CMP, 5). A key component of CMP's analysis is the idea that “the ACC possessor DP originates in a position external to the ACC”—specifically, a theta position—“and moves into its possessor position” via sideward movement (CMP, 2). Collins (2007a) fleshes out this derivation from a minimalist perspective, arguing that this movement is licit even though the moved element does not c-command its trace. I discuss these theoretical issues further along in this paper.

2 The scope of the AAC

2.1 Introduction

Recall that the AAC occurs in two forms, shown in (7).

- (7) a. Gwen's dumb ass husband forgot the beer. (CMP, 9)
 b. Gwen's husband is a dumb ass.

I will call examples like (7)a “canonical” AAC constructions. In the canonical AAC, the a-word is preceded by an adjective (e.g., *dumb*) or a noun, and these two elements serve to modify a noun (e.g., *husband*) attributively. A descriptive schematic of the construction thus looks like (8).

¹ Spears (1998) calls the a-word in the construction that CMP analyze (the ACC) a “metonymic pseudo-pronoun”; he refers to the a-word in the construction that I am analyzing (the AAC) as “discourse *ass*” (Spears 1998, 235).

² CMP state that examples of the AAC like (4)a are “independent of the ACC, and represent regular possessive DPs preceding an adjective which simply happens to be a complex one formed with *ass*” (CMP, 10).

(8) {Adj, N}– a-word – N

Throughout this paper, I will use the term “associate” to refer to the adjective or noun that precedes the a-word.

Example (7)b shows what I will call the [+human] AAC. I analyze this construction as a special case of the AAC, derivable from the canonical AAC in particular circumstances. It will be important to keep the distinction between these two constructions in mind in the following paragraphs in which I describe how the AAC is productive and what restrictions there are on it. The paragraphs below describe the canonical AAC, and where it is relevant, I point out ways in which the [+human] AAC differs from the canonical construction.

2.2 Attributivity

One important fact about the AAC is that the a-word and its associate are nearly always pre-nominal. This fact was first noted by Spears (1998), who put it in these terms: “one syntactic constraint on AWs is that they must be followed by a noun” (Spears 1998, 236).³ This fact about the AAC was also observed by CMP (10). In other words, the AAC cannot generally be used as a predicate, as shown in (9) and the (b) examples in (10)-(12).

(9) *He’s bitch ass. (Spears 1998, 236)

(10) a. Gwen’s crazy ass brother called me again last night.

b. *Gwen’s brother is crazy ass.

(11) a. Jamie has an ugly ass boyfriend.

b. *Jamie’s boyfriend is ugly ass.

(12) a. Gwen has a stupid ass husband.

b. *Gwen’s husband is stupid ass.

It is important to note that a sentence very similar to (10)b is acceptable, and this is when the predicate is a predicate DP, as shown in (13). Example (13) is the [+human] AAC.

(13) Gwen’s brother is a crazy ass.

I will argue further along that even in the case of (13), the AAC is attributive/prenominal; in the [+human] AAC, in other words, the a-word and its associate modify an unpronounced nominal. But as its name implies, the [+human] AAC can only be used to describe [+human] subjects, as shown in (14)a. Note that the canonical AAC, shown in (14)b, has no such [\pm human] restriction.

(14) a. *That coat is a raggedy ass.

b. It’s time for me to throw away that raggedy ass coat.

Although the AAC cannot generally be used as a predicate, there appear to be two exceptions. The cases below show a construction that is allowed in the canonical AAC but disallowed in the [+human] AAC. The (a) examples in (15)-(16) show the canonical AAC, and the (b) examples show how the same a-word associate from the (a) examples cannot be the

³ Spears (1998, 234) uses “AW” for *-ass* words.

modifier in the [+human] construction. The (c) examples show what appears to be a predicative use of the AAC, for some speakers.⁴

- (15) a. Hey, I'm a grown ass man!
 b. *Hey, I'm a grown ass!
 c. Hey, I'm grown ass!
- (16) a. He's a broke ass man.
 b. *He's a broke ass.
 c. He's broke ass.

I will discuss these apparent exceptions to the attributivity of the AAC further along, in section 3.4.1.

2.3 What the AAC can modify

The canonical AAC has few limitations on what it can modify in terms of the features [\pm human] and [\pm animate]. The examples in (17)-(19) show that the canonical AAC is productive in [+human] contexts (17), [-human, +animate] contexts (18), and [-human, -animate] contexts (19).

- (17) a. We some punk ass parents, see.⁵ (Lee 2000, Bernie Mac)
 b. I know country ass people when I see 'em. (Lee 2000, Steve Harvey)
- (18) a. She loves that ugly ass cat.
 b. I got bit in the ass by a stinkin ass filthy dog.⁶
- (19) a. Did you go see that long ass dry movie? (Lee 2000, Steve Harvey)
 b. Asking them dumb ass questions. (Lee 2000, D.L. Hughley)

As the name of the construction implies, the [+human] AAC (20) cannot be used to denote things that are [-human] (21).

- (20) a. My brother is a stupid ass.
 b. Some crazy ass must have done that.
- (21) a. *That cat is an ugly ass.
 b. *My coat is a raggedy ass

⁴ It should be noted that informants did not all agree on the judgments for (15)-(16); for one informant, (15)c-(16)c were ungrammatical. More in-depth informant work needs to be done on apparently predicative cases like these.

⁵ A rough gloss of *punk ass* in (17) is "wimpy." Example (17) is a quote from the film *The Original Kings of Comedy* (Lee 2000). This film contains several different stand-up comedy acts. For all examples from this source, I give the name of the comedian who uttered the example in addition to the standard identifying information, "Lee 2000".

⁶ Quote from the film *Friday* (1995).

2.4 The associate of the a-word

The AAC is productive with a variety of types of adjectives and nouns in the pre-a-word, {Adj, N} position, as shown in (8). The following sections give a sense of the scope of the associate in the AAC. As Spears (1998) shows, the associate of the a-word is not limited to one category. It can be an adjective, a noun, a participle, or even a phrase.

2.4.1 *Adjectives*

The AAC is productive with a variety of semantic types of adjectives. For example, the associate of the a-word can be an adjective that is usually considered inherently gradable (22) or inherently non-gradable (23).⁷

- (22) a. She loves that ugly ass cat.
 b. Scary ass sight ain't it? (Lee 2000, Cedric the Entertainer)
 c. That grumpy ass lady upstairs always be yelling at us.
 d. That filthy ass dog just bit me!
 e. What you laughing at with them thick ass glasses on? (Lee 2000, D.L. Hughley)
 f. It's time for me to throw away that raggedy ass coat.
 g. Gwen's rich ass boyfriend took us all out to eat.
 h. I ain't got time for these bad ass kids. (Lee 2000, Bernie Mac)
 i. That's a lame ass excuse.
- (23) a. My sister's sick ass children always be coughing and sneezing.
 b. If I won the lottery, I'd buy myself a red ass car.
 c. That's Jamie's blond ass girlfriend over there.
 d. I need to find a rich ass boyfriend.

One misconception about the AAC that was first pointed out by Spears (1998, 238) is that the AAC can only be used to express negative evaluation. Spears makes the point that the construction is not inherently positive or negative, and that the evaluative force of an AAC is carried not by the a-word, but by “the formative to which *-ass* is attached” (Spears 1998: 237-238).⁸ Some examples of the AAC used for positive evaluation are shown in (24)-(25).

- (24) [This is] my cute ass friend⁹

⁷ I consider gradable adjectives ones that can have comparative and superlative forms (Barker 2005). As no doubt has been observed, predicates that are conventionally considered non-gradable can be made gradable, for many speakers of English. In my mainstream English, *pregnant* is one such word:

(i) She is very pregnant at this point.

⁸ It may be that the misconception that the AAC can only be used for negative evaluation comes from the fact that when white speakers of mainstream English use the AAC (or constructions like it), it can only be used for negative evaluation.

⁹ <http://www.bebo.com/PhotoAlbums.jsp?MemberId=326136266>

- (25) a. That was a fine ass jumper.
 b. Jamie has a fine ass girlfriend.
 c. That's a friendly ass lady.
 d. Sheila E. is one bad ass drummer.

Two words for positive evaluation that are specific to colloquial AAE are *dope* and *phat*. Although Spears (1998, 238) asserts that these words are not grammatical in the AAC (**dope ass*, **phat ass*), my informants judged them to be acceptable a-word associates, and they offered the examples in (26).

- (26) a. Those are some dope ass sneakers.
 b. She's a phat ass girl.

The AAC is productive with what are called non-subjective adjectives (cf. Kamp and Partee 1995), such as *former* and *fake*. Subjective adjectives are those that are semantically neither intersective nor subjective; in other words, we cannot assume that the denotation of the non-subjective adjective-noun combination is a subset of the denotation of the noun (27). These are adjectives like *potential*: for example, if someone is a potential NFL player, we cannot conclude that the person is an NFL player. A special type of non-nonsubjective adjective is called privative; when a privative adjective is used with a noun, the effect is that the adjective-noun combination is *not* a subset of the noun.

- (27) ||Adj N|| $\not\subseteq$ ||N||

More concretely, *fake* and *ex-* are privative adjectives because a fake diamond is not actually a diamond, and a person's ex-husband is not their husband. The sentences in (28)a-c were taken from Web sites but accepted by my informants; (28)d is a constructed sentence accepted by my informants.¹⁰

- (28) a. (You) fake ass Suge Knight!¹¹
 b. You aint never been in anything that requires ethics you fake ass gangbanger.¹²
 c. We don't want your fake ass Timberlands.¹³
 d. Gwen's old ass boyfriend called last night. (old = ex- or former)

2.4.2 Nouns

An important aspect of the AAC is that it is productive with a noun as the associate of the a-word (29).

- (29) a. We some punk ass parents, see. (Lee 2000, Bernie Mac)
 b. [Everyone is] worrying about this little punk ass boy in jail (Lee 2000, Steve Harvey)

¹⁰ Interestingly, informants reported that the meaning of *old* as 'former' would be the most natural interpretation of (28)d.

¹¹ Quote from the film *Next Friday* (2000).

¹² http://www.defsounds.com/news/Camron_apologizes_for_snitching_comments

¹³ <http://www.hiphopgame.com/forums/showthread.php?t=29630>

- c. Look at my clown ass cousin Jerod.¹⁴

Spears (1998) also mentions nouns like *fool*, *punk*, *bitch* and *ho*. In fact, Spears (1998, 234) discusses AAC as primarily involving a noun as the associate of the a-word. This may be in part because he assumes an analysis in which the AAC is “a type of compound,” though with the *ass* morpheme “semantically bleached” (Spears 1998, 236). I will argue further along that this quality of “semantic bleaching” of the a-word in the AAC suggests that the AAC does not involve compounding.

2.4.3 *Participles and phrases*

The AAC is also productive with participles and phrases, as shown below.

- (30) a. I got a little year older, now I’m a grown ass man. (Lee 2000, Cedric the Entertainer)
- b. Big mama ... [had] those swollen ass ankles. (Lee 2000, Bernie Mac)
- c. Look like a broke ass rapper right there.¹⁵ (Lee 2000, D.L. Hughley)
- d. ... your lying cheating ass boyfriend with that tramp from the other side of town!¹⁶
- e. She’s a triflin ass woman. (Spears 1998, 237)
- f. Stinkin ass rappers make me sick. (Lee 2000, Cedric the Entertainer)
- g. She got a fucked up ass hairdo. (Lee 2000, Bernie Mac)
- h. no dancin ass¹⁷ (Spears 1998, 234)

Despite this productivity with participles, the construction is less productive when the a-word associate has a complement.¹⁸

- (31) *cheating on me ass boyfriend

The apparent exception to this might be with verbs of possession, as shown in (32)a.

- (32) a. ain’t got no rap ass¹⁹ (Spears 1998, 234)
- b. All you no money having ass wanna be rappers mad cuz he better than y’all²⁰

¹⁴ <http://www.youtube.com/watch?v=CIDIJvWyvxI&feature=related>

¹⁵ This example might be misleading, as I suspect *broke* does not have the distribution of a past participle in colloquial AAE.

¹⁶ <http://www.nappyafro.com/Top5MusicVideos.html>

¹⁷ Arthur Spears (p.c.) suggests the following contexts for *no dancin’ ass* (i)-(ii):

- i. His no dancin’ ass was at the party last night
- ii. Why’d you take his no dancin’ ass to the party?

¹⁸ This is reminiscent of a fact about German complement-taking adjectives: in attributive contexts, the complement of such an adjective must precede the adjective (i):

- i. der [auf seinen Sohn] stolze Vater
the of his son proud father

Thanks to a reviewer for pointing this out.

¹⁹ Describes someone who is “unable to speak persuasively” (Spears 1998, 234), as in the following sentence (Arthur Spears, p.c.):

- i. Look at all them lame, ain’t got no rap ass muthafuckas.

²⁰ <http://www.hiphopmusicdotcom.com/lil-wayne-disses-his-dj-in-front-of-the-crowd.html>

Note that this is also true in the domain of adjective associates of the a-word in the AAC. For example, although *proud* is acceptable in the AAC as shown in (33), *proud* cannot take a complement when it is part of the AAC, as shown in (34)b-c.²¹

(33) I'm a proud ass Knick fan proud of our history.²²

- (34) a. John is proud of his son.
 b. *John is (a) proud ass of his son.
 c. *John is (a) proud of his son ass.²³

As I will discuss, these facts are related to attributivity of the AAC.

2.5 Productivity in the [+human] AAC

Recall that the [+human] AAC involves an a-word associate and an a-word, as shown in (2) repeated as (35).

(35) Gwen's husband is a stupid ass.

Example (35) shows the [+human] AAC as a DP predicate in a copular sentence. But the [+human] AAC can occur in other environments as well.

2.5.1 Determiners and syntactic positions

In addition to the determiner *a* (35), other determiners are possible in the [+human AAC], such as *some*, *that*, and *every* (36).

- (36) a. Some crazy ass must have done that.
 b. Look where that fool ass parked.
 c. Now every punk ass in town is going to be wearing that shit.

The [+human] AAC can also occur in a variety of syntactic positions. As we have seen, the [+human] AAC can occur as a predicate DP (35) and in a subject position (36), receiving a theta role. It can also occur as an indirect object or a direct object (37).

- (37) a. I gave that fool ass a piece of my mind!
 b. Gwen finally kicked that fool ass out the house.

One restriction that informant work has begun to reveal is that the [+human] AAC is not possible with a possessor in the determiner position. Consider the following examples, in which Gwen's brother is Jamie. In sentence (38)a, *Gwen's clown ass* cannot refer to Jamie, no matter how salient Jamie is in the discourse; *Gwen's clown ass* must refer to Gwen herself. The same is true for (38)c, in which *her clown ass* can only refer to Gwen, and the sentence is ungrammatical when *her clown ass* refers to Jamie. Grammatical alternatives are given in (38)b and (38)c.

²¹ Arthur Spears (p.c.) points out that one exception is when the AAC is not an argument, as in (i):

i. I saw her with her all proud of her son ass at the graduation

This sentence involves what CMP call the "resumptive *with*" construction in AAE (CMP, 41-46).

²² <http://www.knicksonline.com/forums/showthread.php?p=52070>

²³ Unacceptable on the reading where John is proud of his son; acceptable in the weird circumstance in which John is proud of his son's buttocks.

- (38) a. *Gwen's clown ass is coming over tonight. (when *Gwen's clown ass* == Jamie)
 b. Gwen's clown ass brother is coming over tonight.
 c. *Her clown ass is coming over tonight. (when *her clown ass* == Jamie)
 d. Her clown ass brother is coming over tonight.

The data in (38) raise some very interesting issues regarding the relationship of the AAC to the ACC—a construction in which a possessor is mandatory—since as noted above, (38)a and (38)c are grammatical on an ACC reading, with the referent of *Gwen's clown ass* or *her clown ass* being Gwen. Future informant work will shed more light on these data in particular, and it will also provide a fuller picture of the complete range of determiners and syntactic positions available for the [+human] AAC in general.

2.5.2 Adjectives

In many cases, the same adjective can be used in both the canonical AAC and the [+human] AAC, as shown in (39)-(41) with *fake*, *crazy*, and *stupid*.

- (39) a. Ja Rule was a fake ass rapper.
 b. Ja was a fake ass.²⁴
- (40) a. Gwen has a crazy ass boyfriend.
 b. Gwen's boyfriend is a crazy ass.
- (41) a. Jamie has a stupid ass brother.
 b. Jamie's brother is a stupid ass.

But as I discuss further below, the [+human] AAC in general admits a smaller set of nouns and adjectives than does the canonical AAC, though my informants accepted many of the constructions that Spears (1998) said were not available. In particular, Spears said that although the (b) examples in (42) and (43) are acceptable (in the canonical AAC), the (a) examples were ungrammatical. My informants accepted all of these constructions.

- (42) a. He's a jive ass. (ungrammatical in Spears 1998, 237)
 b. He's a jive ass fool.
- (43) a. He's a rich ass.
 b. He's a rich ass rapper.
- (44) a. He's a bitch ass. (ungrammatical in Spears 1998, 237)
 b. You sound like a bitch ass rapper.²⁵ (KRS-One, "Wannabemcee")

²⁴ <http://realtalkny.rawkus.com/2007/11/topic/topic/news/irv-gottis-compares-50-cent-to-ja-rule/>

²⁵ One informant judged (i) to be acceptable:

(i) Souja Boy is a bitch of a rapper.

In contrast to (45)b (which imparts a negative evaluation), sentence (i) is interpreted as giving a positive evaluation of the subject's rapping skills. This data seems to contradict previous informant work that suggested that the "N of an N" construction is not available in AAE. More investigation needs to be done in this area.

On the other hand, informants rejected the [+human] constructions in the (a) examples in (45)-(46), while accepting the same adjectives in the canonical construction (the (b) examples in (45)-(46)).

- (45) a. *That boy is a tall ass.
 b. That's a tall ass boy.
- (46) a. *Madonna is a famous ass.
 b. Madonna is a famous ass singer.

Some participles and phrases are consistently rejected from the [+human] construction, as shown in (47)-(48). This asymmetry is correlated with some other interesting properties of the AAC, as I will discuss further along.

- (47) a. *I'm a grown ass.
 b. I'm a grown ass man.
- (48) a. *He's a broke ass.
 b. He's a broke ass rapper.

2.6 Properties of the a-word

2.6.1 *Lack of inflection*

One clue to the nature of the a-word in the canonical AAC is that it resists being inflected. In this way, it has a property of a light (or perhaps bare) noun like *home*, as discussed by Collins (2007b, 10, 13; cf. Kayne 2005c, 256ff.). First, the a-word in the AAC cannot be a possessor, as shown in the canonical AAC in (49), and the [+human] AAC in (50).²⁶

- (49) a. *Jamie's ugly ass's car is broken.
 b. Jamie's ugly ass car is broken.
- (50) a. *Some stupid ass's car is parked in my spot.²⁷
 b. Some stupid ass parked in my spot.

Though note that the whole constituent can be a possessor (51).

- (51) Jamie's ugly ass car's fender is broken.

In the canonical AAC, the a-word cannot be made plural, as shown in (52).

- (52) a. *There are some crazy asses people who live on my street.
 b. *You should throw away them ugly asses clothes.
 c. *Our stupid behinds boyfriends forgot the beer again.
 d. *I'm gonna sue those rich asses people!

²⁶ The a-word in the AAC cannot be a possessor either, as shown by CMP:

(i) *His ass('s) car is ugly. (CMP example 15d, p. 15)

²⁷ As I will discuss further along, example (50) actually shows that unpronounced PERSON cannot be a possessor.

The two generalizations above hold for the canonical AAC. In the [+human] construction, the facts about pluralization are less clear, as I will discuss further along. Informants accepted (53)a, but half of them rejected (53)b. (I use “%” to indicate split judgments.)

- (53) a. Those people are a bunch of lazy asses!
 b. % I bet some crazy asses did that.

I will discuss the implications of these varying judgments on plurals in the [+human] AAC in 5.2.1.1.

2.6.2 *The a-word is not restricted to ass*

CMP make the point that the a-word in the ACC is not limited to *ass* but can be *butt*, *behind*, or *tail*, words that in that their literal usage denote the body part, and that the alternate mask *behind* can be used in situations where swearing is not appropriate (CMP, 10). The AAC also makes use of these alternate a-words, and my informants echoed CMP’s statement that the alternates would be used in situations where swearing was not appropriate, for example, when there are children around or people who are easily offended by strong language (CMP, 10). But the AAC allows for less leeway in alternate a-word masks. Although (54) from CMP shows three acceptable a-words in the ACC that aren’t *ass*, the same masks were not all accepted by my informants for the AAC.

- (54) I’m gonna fire his sorry ass/behind/butt/tail. (CMP, 10)

Informants accepted *behind* and *butt* in the canonical AAC, as shown in (55), but rejected *tail* and *fanny* (56).²⁸

- (55) a. Gwen’s stupid behind husband forgot the beer again.
 b. Gwen’s stupid butt husband forgot the beer again.
 (56) a. *Gwen’s stupid tail husband forgot the beer again.
 b. *Gwen’s stupid fanny husband forgot the beer again.

The unacceptability of *fanny* in (56)b is not surprising; CMP make the point that *fanny* is not acceptable in the ACC (CMP, 10). It’s interesting to note that one informant observed that although both *fanny* and *tail* are bad, *tail* is definitely not as unacceptable as *fanny*. This observation may suggest in a qualitative way that the ACC and the AAC have structural similarities, though it doesn’t explain why some masks are acceptable in the ACC and not in the AAC.

In the [+human] AAC, the most accepted alternative a-word is *butt*.

- (57) a. Gwen’s boyfriend is a stupid butt.
 b. Gwen’s boyfriend is a crazy butt.

Both *fanny* (as expected) and *tail* were rejected; some informants rejected *behind*, and some accepted it.²⁹

- (58) a. *Gwen’s boyfriend is a stupid fanny.

²⁸ One informant, who visits family in North Carolina, commented that in his experience, *fanny* was generally not used at all, this far north.

²⁹ Arthur Spears (p.c.) notes that rhythmic/metrical constraints may be affecting judgments on these data.

- b. *Gwen's boyfriend is a stupid tail.
- c. % Gwen's boyfriend is a stupid behind.

2.6.3 *The a-word doesn't affect truth conditions*

As noted above, Spears (1998, 236-237) was the first to observe that the a-word in the AAC does not carry the same semantic load as it does in its literal use. Similarly, CMP describe the a-word in the ACC as “semantically vacuous” (CMP, 40), and making no contribution to the truth value of a sentence containing it. The same is true for the a-word in the AAC. In other words, the truth conditions for (59)a-c are the same: all three are evaluated in terms of whether the property of going to get in trouble is true of Gwen's brother. Similarly, the truth conditions for (60)a-b are the same.

- (59) a. Gwen's lazy brother is gonna get in trouble.
- b. Gwen's lazy ass brother is gonna get in trouble.
- c. Gwen's lazy behind brother is gonna get in trouble.
- (60) a. Take off that ugly coat!
- b. Take off that ugly ass coat!

Smitherman (1994, 2000, 56-57), states that *ass* serves to give an expression “extra emphasis,” but Spears (1998) disagrees. Spears claims that the AAC “may in specific utterances have the force of an intensifier,” but he states that “this is not always the case” (Spears 1998, 236). In fact, AAC expressions can be further intensified, at least with *damn*, as shown in (61).

- (61) He wears the same damn ugly ass tie every day!

These fact will be important to keep in mind when discussing a possible analysis of the AAC as involving focus.

2.6.4 *Stress pattern*

Although I have argued with reference to (59)-(60) that the presence of the a-word does not have a truth conditional effect, it *is* the case that stress on the a-word can affect truth conditions. It should be noted first that the a-word mask in the canonical AAC cannot be stressed relative to its associate. This fact has been observed by Spears (1998, 236) and discussed by CMP with respect to the ACC. This stress pattern—with the a-word resisting stress—is an important point of commonality between the AAC and the ACC.

CMP discuss the lack of stress on the a-word in the ACC specifically in terms of the a-word resisting focus. Focusing the a-word forces a literal interpretation, and a stressed a-word cannot be an ACC mask. CMP give the following example (62), in which continuation (a) with *it* is felicitous only when *butt* is stressed, making the use of *butt* a literal rather than a camouflage use.

- (62) The doctor said he gon operate on her butt, (CMP example 65, p. 26)
- a. ...even though it looked alright to us.
- b. ...even though she looked alright to us.

The two complete (grammatical) continuations are shown (63)-(64). In (64), the a-word is not stressed, resulting in the camouflage interpretation; in (63), the a-word is stressed, forcing a literal interpretation of *butt* as buttocks (shown by the pronoun *it* further on in the sentence). In other words, stress has a truth-conditional effect in the ACC. (Capitalization indicates phrase-level stress.)

(63) The doctor said he gon operate on her BUTT, even though it looked alright to us.

(64) The doctor said he gon operate on her butt, even though she looked alright to us.

Turning now to the AAC, we find that stress also affects the truth conditions, though not in a completely analogous way. This is particularly evident in the [+human] AAC. Consider the sentences in (65).

(65) a. Jamie's brother is a STUPID ass.

b. Jamie's brother is a stupid ASS.

The normal phrasing of the [+human] AAC is shown in (65)a. Here, the a-word associate is stressed. For truth conditions, the most important thing to note about these sentences is that sentence (65)a does not entail that Jamie's brother is an unpleasant person; sentence (65)b does. Furthermore, the interpretation of *stupid* also changes between the two contexts. In (65)a, the quality of being clownish or silly is being predicated of Jamie's brother. In (65)b, on the other hand, Jamie's brother is being described as a jerk or asshole, and an unintelligent one; in other words, in (65)b the a-word makes a semantic contribution to the truth conditions of the sentence. This suggests a structural difference between (65)a and (65)b.

Notice that the alternation in (65) is possible because *ass* can be used either in a semantically vacuous way (as part of an AAC) or in a semantically contentful way, with the meaning of "jerk." The fact that in the AAC the a-word is obligatorily not stressed is highlighted when we use other a-words in the AAC, words that do not have the meaning of "jerk." For example, the word *butt* is acceptable in the [+human] AAC as shown in (66)a.

(66) a. That guy is a LAZY butt.

b. #That guy is a lazy BUTT.

(67) a. Quit being such an ASS.

b. #Quit being such a BUTT.

Because the word *butt* cannot be used as a normal noun to describe a person (67)—or, to put it differently, cannot have a nominal meaning in this context aside from referring to buttocks—example (66)b simply doesn't make sense. The only interpretation of (67)b is the nonsensical one that attributes the quality of being buttocks to a person.

3 The Canonical AAC

3.1 Introduction

As we have seen, the AAC is stubbornly attributive, exemplified by the ungrammaticality of (68).

(68) *Jamie's brother is crazy ass.

In the preceding sections, I have made a distinction between the canonical AAC (69)-(70) and the [+human] AAC (71).

- (69) Jamie has a crazy ass brother. *canonical AAC*
- (70) You should get rid of that raggedy ass sweater *canonical AAC*
- (71) Jamie’s brother is a crazy ass. [+human] AAC

In this section, I focus on the canonical AAC and show that it is best analyzed as involving movement from a predicational to an attributive position. In particular, I argue that the AAC involves remnant movement of the modifier (e.g., *raggedy*) from a predicative, small clause-like position into a constituent with the a-word, and then into attributive (prenominal) position. This analysis is sketched out in (72); the following sections will more fully motivate and describe this structure.

(72)

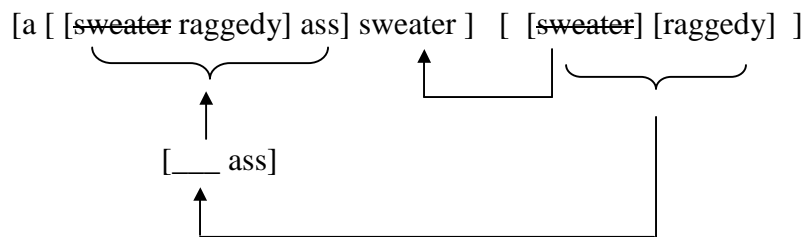

This analysis relies on a relative clause analysis of attributive modification (Smith 1961, Kayne 1994, Alexiadou 2001, Leu 2008, inter alia), and a camouflage structure (CMP). Note that although it appears that the [+human] AAC (71) might have a different analysis from (69) and (70), I will argue that the [+human] AAC is also attributive, derived from the canonical AAC and hence just a special case of the canonical construction. Before turning to a derivation of the canonical AAC, I must first explain some of the assumptions that my derivation makes use of, the relative clause analysis of attributive adjectives and sideward-interarborescent movement (Nunes 1991, 1995, Bobaljik and Brown 1997, Collins 2007a).

3.1.1 Relative clause analysis

Kayne (1994), building on earlier work such as Smith (1961), argues that attributive adjectives are derived from a relative clause structure, as shown in (73):

- (73) the $[_{FP} F^0 [_{CP} [_{XP} \text{yellow}_j] [C^0 [_{IP} [\text{book}] [I^0[e]_j]]]]]]$ (Kayne 1994, 101)

Kayne shows that prenominal adjectives in Germanic and postnominal adjectives in Romance can both be derived from the same source. The advantage of this analysis is that in addition to showing the analogy between the extended domain of N and the extended domain of V, it also derives adjective ordering without N movement, and it shows that we do not need to adopt two different analyses for reduced relative-type adjectives (e.g., *a man proud of his son*) and attributive adjectives (e.g., *a proud man*) (cf. Cinque 1994). In (73), the adjective phrase, XP, has been preposed from a predicate position within the IP to Spec-CP. This derives the prenominal ordering of attributive adjectives in English, for example. Postnominal attributive adjectives in

Romance are the result of further movement of the noun in Spec-IP through C^0 up to the functional head F^0 .

3.1.2 Sideward movement

The analysis that I propose makes use of sideward movement (Nunes 1995, 2001), also called “interarboreal head XP movement” (Bobaljik and Brown 1997). This type of movement also plays a key role in Collins’s (2007a) derivation of ACC (camouflage) constructions. Because different authors discussing these types of movement use slightly different terminology, I will clarify how I use these terms in this paper.³⁰ I use “sideward” as the more general term, to describe any movement that is neither upward (to a c-commanding position—the most uncontroversial kind of movement) nor downward (to a c-commanded position). I use “interarboreal” to describe movement from one tree to another when the trees are not connected (neither position dominates the other, and the trees are not connected). Bobaljik and Brown (1997, 353-354) would call the type of movement that Collins’s (2007) analysis makes use “interarboreal XP movement.” Strictly speaking, this type of movement involves both sidwards and interarboreal movement. I will simply refer to this movement as interarboreal.

The motivating idea behind this kind of movement originally came from the fact that derivations as they are done today involve the building up of structures in parallel, at least to some extent. For example, in a sentence with a DP subject, both a VP and the DP must be built up in the workspace, in parallel, until the DP subject eventually merges to the Spec-VP position. Bobaljik and Brown (1997) illustrate this process with a sentence like (74) (Bobaljik and Brown’s example (5), shown with tense inflection).

(74) The monster ate the pizza.

The DP *the pizza* is built up, then merged with *ate*. Also in the workspace, the DP *the monster* is built up. Only after these two structures are built up is the DP subject *the monster* merged to the specifier of the VP *ate the pizza*.

Nunes (1995, 2001) argues that derivations like the one I sketched for (74) show that, in theory, “constrained instances” of what he calls “sideward movement” are possible (Nunes 2001, 304). Both Bobaljik and Brown (1997) and Nunes (2001) constrain these types of movement by saying that sideward movement can only happen if the sideward movement is followed by interarboreal movement such that a moved element c-commands its trace, following Rizzi’s (1986b) “Chain Condition” and Chomsky’s (1995) C-Command Condition. Collins (2007a) proposes that because of camouflage constructions like the ACC, the C-Command Condition should be abandoned as a condition on movement; Collins suggests that just the Extension Condition (Chomsky 1993) be retained. Collins’s (2007a) derivation adheres to the Extension Condition, as will my own derivation of the AAC, which utilizes very similar movement operations as those in Collins (2007a).

3.2 Deriving the canonical AAC

In the following paragraphs, I show how the relative clause analysis of attributive adjectives and sideward-interarboreal movement come together in the AAC. Let us take as an example the derivation of *a raggedy ass sweater* in (75).

³⁰ There are more terms than just “interarboreal” and “sidwards” to describe these kinds of movement. Uriagereka (1998, 311, 314) uses “parallel” and “paracyclic” to describe what I am calling “interarboreal.”

(75) That's a raggedy ass sweater he's got on.

The derivation starts with an initial predication relationship between *raggedy* and *sweater*. In the structure below, I show this relationship using an Infl projection in which there is a null copula (76).

(76) $[_{IP} I^0 [_{VP} [_{DP} \textit{sweater}] [_{AP} \textit{raggedy}]]]$

The first step in the derivation is the movement of the DP *sweater* out of that constituent structure to Spec-IP (77)a-b. This movement is analogous to subject movement to Spec-IP in a normal clause.

(77) a. $[_{IP} [_{DP} \textit{sweater}] [_{I'} [I^0 [_{VP} [_{DP} \textit{sweater}] [_{AP} \textit{raggedy}]]]]]$

 b. $[_{IP} [_{DP} \textit{sweater}]_j [_{I'} [I^0 [_{VP} [_{DP} \textit{sweater}]_j [_{AP} \textit{raggedy}]]]]]$

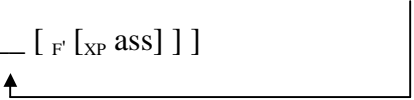
In a non-AAC construction, the next step would be the raising of the predicate, *raggedy*, in this case. This still happens, but in the AAC, the AP first moves sideways to the Specifier of a shell that is the extended projection of an a-word. Let us call this projection FP for now. This movement is shown in (78)a. Because the predicate moves into the camouflage shell while it is already moving—viz., undergoing predicate raising—I call this type of movement *hijacking*. The constituent resulting from this hijacking is shown in (78)b.

(78) a. $[_{IP} [_{DP} \textit{sweater}]_j [_{I'} [I^0 [_{VP} [_{DP} \textit{sweater}]_j [_{AP} \textit{raggedy}]]]]]$

 b. $[_{FP} [_{AP} \textit{raggedy}] [_{I'} [_{XP} \textit{ass}]]]$

The step of movement into the camouflage constituent FP while undergoing predicate raising (hijacking) is an important one in accounting for certain facts about the AAC, as I will discuss further along. What I call hijacking is also what happens in Collins's (2007a) derivation of at least some cases of the ACC, in which a DP moves sideways to the specifier of a DP built on an a-word.

The final step of the derivation is the continuation of the predicate raising that happens with all attributive adjectives. This movement is interarboreal movement, since a tree that has been built up in parallel (the extended projection of the a-word) is merged to another tree (in this case, the main tree). The predicate *raggedy*, now camouflaged in the extended projection of the a-word ((78)b), moves to Spec-CP. The resulting structure is shown in (79).

(79) $[_{CP} [_{FP} [_{AP} \textit{raggedy}] [_{I'} [_{XP} \textit{ass}]]]] [_{C^0} [_{IP} [_{DP} \textit{sweater}]_j [_{I'} [I^0 [_{VP} [_{DP} \textit{sweater}]_j [_{AP} \textit{raggedy}]_i]]]]]]]$

Note that the whole CP is the complement of a DP. This complete structure is shown in (80). The movement operations involved have been predicate raising, interrupted by sideward movement, followed by interarboreal movement, which in the case of the AAC is the continuation of predicate raising.

(80)

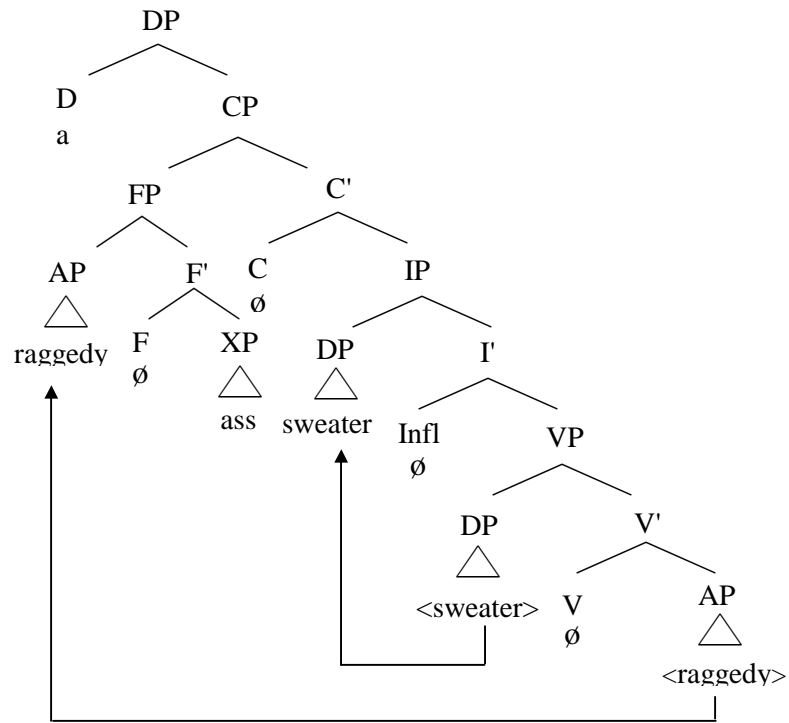

As a comparison, (1) shows the tree for the non-AAC phrase *a raggedy sweater*.

(81)

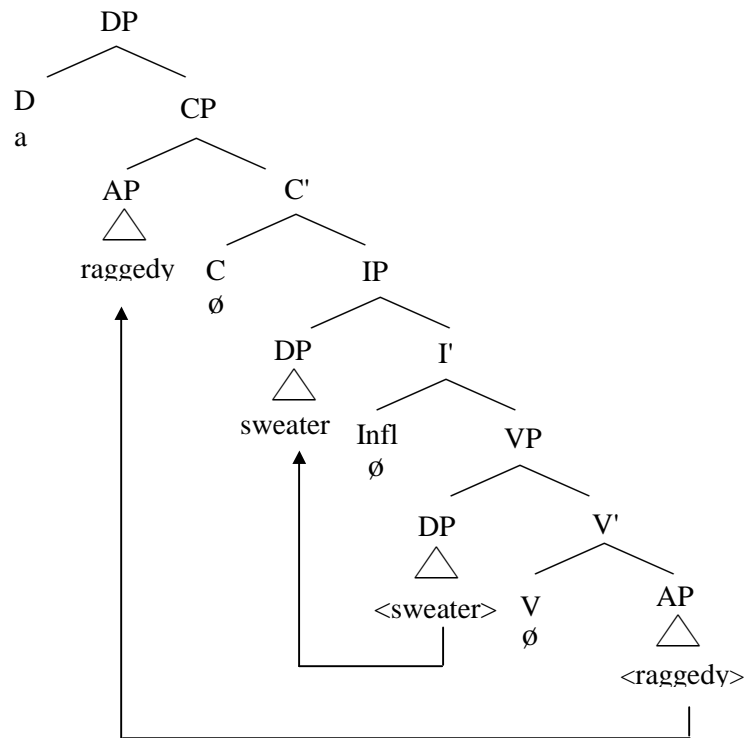

the right track, then it would start to explain why speakers have a sense that the a-word serves to intensify the meaning of the a-word associate (e.g., *raggedy*). I discuss this possibility further in section 4.2.³²

3.4 Syntactic consequences

What are the syntactic consequences of the structure in (80)? In particular, one question worth asking is what the syntactic effect is of the fact that the modifier (e.g. *raggedy*) has moved into a shell constituent with the a-word. In the following sections, I explain how this analysis accounts for the attributivity of the AAC, the productivity of non-adjectival (e.g., nominal) modifiers in the AAC, the lack of agreement between the a-word and the head noun, and facts about how the AAC patterns with light nominal phrases (e.g., *someone*).

3.4.1 *Attributivity*

Unlike some languages, English is a language in which an adjective can function as a predicate, as shown in the following sentence from mainstream English.³³

(83) That sweater is ugly.

Recall that in the AAC, the a-word and its associate cannot function as a predicate. In other words, the (b) examples in (10)-(12), repeated below as (84)-(86), are ungrammatical.

(84) a. Gwen's crazy ass brother called me again last night.

b. *Gwen's brother is crazy ass.

(85) a. Jamie has an ugly ass boyfriend.

b. *Jamie's boyfriend is ugly ass.

(86) a. Gwen has a stupid ass husband.

b. *Gwen's husband is stupid ass.

In each case in (84)-(86), the a-word and its associate cannot function as a predicate adjective. Why would this be? I argue above that the AAC was parasitic on predicate raising. When the adjective or nominal predicate raises from a relative clause source, it first moves sideways into the extended projection of an a-word. The unavailability of the AAC in predicate position suggests that predicate adjectives have a different source than attributive adjectives, and that they do not undergo predicate raising as attributive adjectives do. The (b) examples in (84)-(86) could only come about if the adjective in each sentence was first merged with the subject DP, and then underwent predicate raising. The fact that the (b) examples are ungrammatical suggests that the adjective in these predicate adjective sentences does not undergo predicate raising, or at least not in the same way as an attributive adjective does. The adjective therefore never has a chance to move into a constituent with the a-word.

³² The notion of semantic “bleaching” raises the issue of what precisely the semantic interpretive component does with the constituent formed by merging, say, *raggedy* with *ass*. CMP suggest two possibilities for camouflage *ass*: either that it is not seen by the semantic component, or that it constitutes an identity function (CMP, 17). The same might be true of the a-word in the AAC. Another possibility is that the a-word makes the kind of contribution that degree words make. I leave this aspect of the semantic component of the a-word for further research.

³³ Cinque (2005) discusses languages with attributive adjectives only, and predicate adjectives only.

These patterns involving the AAC may be related to the well-known patterns of agreement in Germanic adjectives: in many Germanic languages with adjectival agreement, attributive adjectives agree with the modified noun, while predicative adjectives do not agree with the modified noun.³⁴ Examples (87)-(88) illustrate these facts for standard German.³⁵ In (87), the predicate adjective *gut* ‘good’ does not agree in gender and number with the noun *Kaffee* ‘coffee’; the examples in (88) show that when used attributively, the adjective must agree in gender and number with the noun.

- (87) der Kaffee ist gut
 the coffee is good
- (88) a. der gut-e Kaffee
 the pretty+AGR coffee
- b. *der gut-∅ Kaffee
 the pretty coffee

In other words, the AAC is available in the same environment as adjectival agreement in German (viz., attributively). Although I will not assume an analysis here for predicate adjectives, the similarity of the AAC with these Germanic adjectival agreement patterns is striking. These facts give further support for the idea that the derivational source of predicate adjectives is different from that of attributive adjectives.

In section 2.2, I noted two apparent exceptions to the attributivity of the AAC (examples (15)-(16)). Because these apparent exceptions are intimately connected to my analysis of the [+human] AAC, I will delay my discussion of examples (15)-(16) until after I present the analysis of the [+human] AAC.

3.4.2 *Nominal modifiers in the AAC*

One advantage of the analysis in (80) is that it accounts for why the modifier in the AAC can be some category other than an adjective. The AAC is particularly productive with nominal modifiers such as *punk* and *fool* as shown in (89).

- (89) a. We some punk ass parents, see.³⁶ (Lee 2000, Bernie Mac)
- b. You fool ass boy if it wasn’t for Mele Mel there would be no [Tu]pac.³⁷

As I have noted, the two constituents in the initial predication relationship can be either a noun and an adjective, or two nouns.³⁸ One syntactic effect of the presence of the a-word is that it

³⁴ A reviewer points out that in general, North Germanic has adjectival agreement in both attributive and predicative position, and West Germanic has no agreement in predicate position, though there are some dialects that are exceptions.

³⁵ Many thanks to Tom Leu for the German examples.

³⁶ Regarding this example, it will be interesting to explore what the status of *punk-like parents* would be.

³⁷ <http://p099.ezboard.com/fpoliticalpalacefrm57.showMessage?topicID=390.topic>. To place this quote in context: Mele Mel was a groundbreaking rapper from the 1970s and 1980s; Tupac Shakur was a popular rapper in the next generation, starting around the 1990s.

³⁸ This analysis then extends to mainstream English constructions involving noun-noun modification, as shown by “lawyer friend” in a sentence like (i):

(i) Have you talked to your lawyer friend yet?

seems to make nominals (more) acceptable as modifiers. Note, for example, that sentences like the following are acceptable with or without the a-word, as shown in (90)-(91). The a-word associate in these sentences is an adjective.

- (90) a. You got some big ass teeth. (Lee 2000, D.L. Hughley)
 b. You got some big teeth.
- (91) a. my cute ass friend³⁹
 b. my cute friend

But in sentences in which the a-word associate is a noun, informants judged the corresponding sentence without the a-word is degraded (indicated with “?”), as shown in (92)-(93).

- (92) a. We some punk ass parents.
 b. ?We some punk parents.
- (93) a. You sound like a bitch ass rapper.
 b. ?You sound like a bitch rapper.

As noted above, there is no semantic, truth-conditional effect on the presence or absence of the a-word in these sentences, but the a-word does make a syntactic difference when the a-word associate is a noun; there appears to be something about being in a constituent with an a-word that makes an ordinarily infelicitous attributive nominal modifier into an acceptable attributive modifier.⁴⁰

3.4.3 *Lack of agreement*

One phenomenon that the camouflage analysis explains is why the a-word never agrees with the noun that it ends up being in a constituent with (94).

- (94) I should get rid of those raggedy ass(*es) sweaters.

This lack of agreement results from both the general fact that English pre-nominal modifiers do not show number agreement, and the specific fact that the a-word and the head noun never form a constituent (except at the end of the derivation, as part of the complex FP). Recall that in the derivation of (94)a, *sweaters* is initially in a predication relationship with *raggedy*, before it raises to Spec-IP and before *raggedy* undergoes predicate raising. But in no point of the derivation is *sweaters* a constituent with *ass*. This analysis also explains the tight connection between the modifier (*raggedy*, in this case) and the a-word: they form a constituent.

3.4.4 *Participle adjectives and adjectives with complements*

Recall that the AAC is also productive with participle adjectives, as shown below (95).

Of relevance for the [+human] AAC further along might be the fact that in mainstream English we can't say (ii); we must say (iii):

- (ii) *Your friend is lawyer.
 (iii) Your friend is a lawyer.

³⁹ <http://www.bebo.com/PhotoAlbums.jsp?MemberId=326136266>

⁴⁰ It may be relevant here that informants strongly rejected the N of an N construction.

- (i) *Gwen's fool of a boyfriend forgot the beer again.

One informant remarked whatever dialect this was, it was definitely *not* African American English.

- (95) a. ... with ... those swollen ass ankles (Lee 2000, Bernie Mac)
 b. Now I'm a grown ass man (Lee 2000, Cedric the Entertainer)
 c. She got a fucked up ass hairdo (Lee 2000, Bernie Mac)
 d. My cousin Kendra and her cheating ass boyfriend⁴¹

We can take these modifiers like *swollen* and *grown* as reduced relatives just as we have analyzed attributive modifiers thus far (Kayne 1994, 98-99). The structure of reduced relatives explains why modifiers with complements cannot be prenominal: the predicate in a reduced relative doesn't raise if it has a complement (96).

- (96) a. I'm a proud ass Knick fan, proud of our history⁴²
 b. a proud ass Knick fan
 c. a Knick fan proud of our history
 d. *a proud of our history Knick fan
- (97) a. *a proud ass of our history Knick fan
 b. *a proud of our history ass Knick fan
 c. *a Knick fan proud ass of our history

In sentences like (96)c, the predicate *proud of our history* does not undergo predicate raising. If it does, the result is ungrammatical, as shown in (96)d. The lack of predicate raising accounts for the fact that the adjective and its complement are post-nominal. Recall that the AAC relies on predicate raising; if the predicate doesn't raise, it does not have a chance to move to the camouflage constituent, and the AAC doesn't happen. Because there is no predicate raising in (96)c, the AAC is not possible with it. In other words, the sentences in (97) are unacceptable for the same reason that (96)d is.

4 Alternative analyses

Two possible analyses of the AAC involve a Cinquean approach to attributive modification, and an entirely different analysis of the a-word as a Degree marker. In this section, I consider these analyses and show their weaknesses in comparison with my own analysis involving predicate raising and camouflage.

4.1 Cinquean approaches

One approach to attributive adjectives posits a fixed structure of functional adjectival heads within the DP (Cinque 1994, Bernstein 1993, Laenzlinger 2005). Adjective phrases are then merged into the Specifiers of these functional heads, in the same way that adverbs are claimed to be merged into Specifiers of functional heads in the IP domain (Cinque 1999). This approach claims to account for cross-linguistic similarities in adjective ordering, though Svenonius (2008) suggests that this approach is ultimately more descriptive than explanatory.

⁴¹ <http://www.bebo.com/PhotoAlbums.jsp?MemberId=326136266>

⁴² <http://www.knicksonline.com/forums/showthread.php?p=52070>

Putting aside that criticism for the moment, let us see what such an analysis might predict for the AAC.

In a Cinquean approach to attributive adjectives, adjectival structure is built into the DP hierarchy. Functional heads sit in the region between D and NP, and adjectives are merged to the specifiers of these heads.⁴³ Each functional head that hosts an adjectival projection has a semantic specification, and only the adjectives that match that semantic specification can be merged to the specifier of that functional head. For example, an adjective phrase headed by *big* would be merged to the specifier of the functional head Adj_{SIZE} . In this way, the Cinquean approach claims to explain cross-linguistic ordering facts, such as the fact that size adjectives in English precede color adjectives (98).

(98) SIZE > COLOR

The following tree shows the structure of the DP *a big red balloon* on a Cinquean analysis (99). The AP headed by *big* is merged to the specifier of the functional head subcategorized for size adjectives, and the AP headed by *red* is merged to the specifier of the functional head reserved for color adjectives.

(99)

How would we analyze the AAC using the Cinquean approach to adjective ordering? The simplest possibility would be that the adjective is first merged into an a-word camouflage shell before it is ultimately merged into the specifier of the appropriate functional adjectival head. But if adjectives are always merged to the specifiers of functional heads, then the adjective would

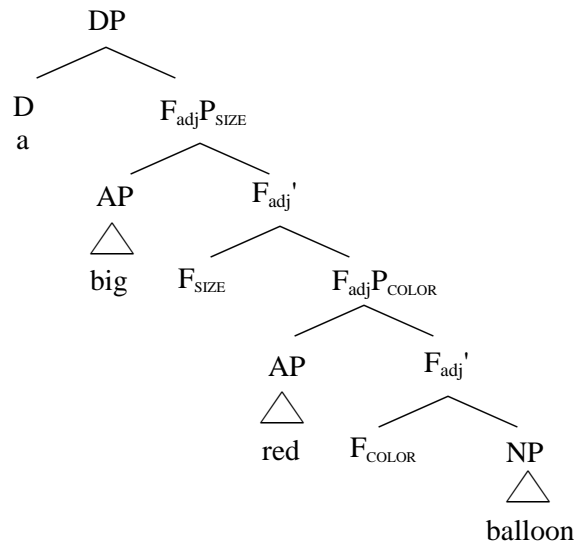

have to be merged to the specifier of a functional adjectival head in the camouflage constituent.

(100) [DP [D' [D⁰] [FADJP [AP big] [FADJ' [FADJ⁰] [NP ass]]]]]

⁴³ Abney (1987) had the adjectives themselves sit as full projections between D and NP, as shown in the following structure from Laenzlinger (2005, p. 651, fn. 6):

(i) [DP D⁰ [ADJP ADJ⁰ [NP N⁰]]]

Laenzlinger notes that this structure “cannot be licensed as such on the grounds of categorial selection.” In other words, it makes the counterintuitive claim that determiners select for adjectives, and adjectives select for nouns.

This analysis runs into trouble at the next step, because the camouflage shell is a DP, and this is no longer able to be merged to the specifier of a functional adjectival head in the main tree. And because *big* is merged into the Spec-FAdj_{SIZE} of the extended ass projection, this analysis also gets wrong the intuition that in a phrase like *big ass teeth*, that *big* describes *teeth*, not *ass*.

Is there another possible Cinquean analysis that avoids these pitfalls? One possibility is that the a-word is actually the *head* of the functional adjectival projection. In this analysis, then, an a-word like *ass* is simply a head that happens to be pronounced in AAE and other dialects of English. The AAC could be made to show evidence for the Cinquean approach to adjectives, since in this dialect we have overt pronunciation of this head. The tree below shows what this analysis looks like for the DP *some big ass teeth* (101).

(101)

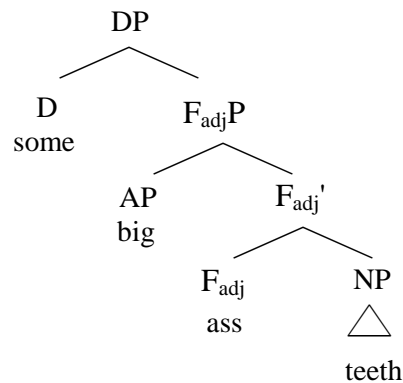

4.1.1 Advantages of a Cinquean approach

This analysis captures several important facts about the AAC. Due to the “semantically bleached” aspect of the a-word in the AAC, it makes sense that the a-word is functional. Further, the a-word is never inflected in the AAC.⁴⁴ It also explains the tight connection between the modifier (e.g., *big*) and the a-word (e.g., *ass*). This analysis also has the advantage of predicting that the AAC can never be predicative as shown in (102), since in this paradigm, predicative adjectives have a different (reduced relative clause) source, presumably in a structure without the F_{ADJ} head.

(102) *Your teeth are big ass.

One potential objection to this analysis is that it makes *ass* appear to be an adjective. This, however, is not a valid criticism because it is the head of the AdjP that is merged to the spec of Fadj that is the adjective, not the functional head that hosts the AdjP in its specifier. It could be argued that a silent nominal COLOR is the head of the functional adjectival projection hosting color adjectives, so that *red balloon* is really *red* COLOR *balloon* (with overt pronunciation of COLOR in some circumstances). If anything were to be the head of one of these projections, it would seem to be a nominal; *ass* is therefore not ruled out as one of these heads, in principle.⁴⁵ But there are other problems with the Cinquean analysis, as I will discuss below.

⁴⁴ It should be noted, however, that speakers sometimes accept plural *ass* in the [+human] AAC, as I will discuss below.

⁴⁵ An informant gave a “maybe” to the sentence in (i).
 (i) He drives a red ass color car.

4.1.2 Weaknesses of a Cinquean approach

One problem with a Cinquean approach as I've outlined it here involves the fact that the functional heads in the Cinquean cartography all fall into some semantic category or other. Each functional adjectival head in the Cinquean hierarchy has some semantic content that contributes to the interpretation of the adjective phrase merged to its specifier. For example, adjective phrases that have to do with color, like *red*, are externally merged to the specifier of the F_{COLOR} projection, size adjectives to the specifier of F_{SIZE} , and so on. There's some disagreement about precisely which heads exist in the Cinquean hierarchy, but all Cinquean approaches to attributive adjectives have in common this idea of functional heads having some sort of semantic specification. If *ass* is thus one of these functional heads, then it is unclear what sort of semantic content this head would give to the interpretation of the adjective merged to its specifier. What kind of functional adjectival projection would an F_{ASS} head be? It could be argued that F_{ASS} lends some sort of affective interpretation to the adjective in its specifier. This appears to be a reasonable hypothesis, but the question that immediately arises is where in the Cinquean hierarchy the F_{ASS} head sits. Constructions with multiple adjectives, some with *ass*, do respect well-known adjective ordering restrictions. If this is the case, then it must be that F_{ASS} can substitute for any of the usual functional heads in the Cinquean adjectival hierarchy. For example, consider the sentences in (103).

- (103) a. You got some big ugly teeth.
 b. You got some big ass, ugly teeth.
 c. You got some big, ugly ass teeth.

On a Cinquean analysis (following Laenzlinger 2005, 655), the F_{ASS} projection would substitute for F_{SIZE} in (103)b and for F_{FORM} in (103)c. But having such optionality seems to violate the spirit of the Cinquean cartography: if ordering in the Cinquean hierarchy is determined by selectional restrictions among the functional adjectival heads (e.g., $\text{SIZE} > \text{FORM}$), then how would it be that when *ass* enters the picture, the ordering restrictions are still respected? This analysis pushes us to the conclusion that there are multiple F_{ASS} heads, each synonymous with the different heads in the hierarchy. And it is the case that multiple AAC constructions are acceptable in modification of a single noun, as shown in the sentences in (104).⁴⁶

- (104) a. the dumb ass wack ass actor should have still been using a condom.
 b. just another lame ass sad ass excuse of a man
 c. a gold-diggin, triflin ass, no-talent having, pineapple-headed ass hoe

And since multiple AAC constructions still respect adjective ordering,⁴⁷ we would have to be more specific and say that we have $F_{\text{ASS.SIZE}}$, $F_{\text{ASS.COLOR}}$, and so on. In other words, there would

Further work needs to be done to get a fuller picture of the judgments on data like (i).

⁴⁶ All are from: <http://www.thelifefiles.com/eddie-murphy-mel-b-tricked-me-into-having-baby/>

⁴⁷ Though as some have noted (Sproat and Shih 1988, Laenzlinger 2005, Svenonius 2008), violating adjective ordering does not always result in ungrammaticality. In my mainstream English, both (i) and (ii) are acceptable, but (ii) definitely feels less natural (I indicate the less natural-sounding sentence with "?".)

(i) A big red ball.
 (ii) ? A red big ball.

Informants had similar judgments, shown below, with both (iii) and (iv) acceptable, but (iii) being less natural-sounding.

have to be an F_{ASS} synonymous with F_{SIZE} , an F_{ASS} synonymous with F_{COLOR} , an F_{ASS} synonymous with F_{FORM} , and so on, resulting in multiple homophonous entries of *ass* (not to mention *behind*) in the Lexicon. I would argue that this result is an undesirable one.

One final weakness of this approach is it goes against the hunch that there are structural similarities between the AAC and the camouflage construction (ACC) analyzed by CMP. In theory, it does not have to be the case that these two forms are related, but I would argue that it is a desirable quality in an analysis of the AAC. Consider the following lines from Steve Harvey’s opening monologue (Lee 2000):

- (105) a. How y’all doin with y’all country ass?
- b. You know your ass is country! Don’t be looking around!
- c. I’m country my damn self, that’s how I know country ass people when I see ‘em.

It would be very surprising that there were no structural relationship between *y’all country ass* (105)a, *your ass is country* (105)b, and *country ass people* (105)c.

4.2 The a-word as a Degree word

One possible analysis is that *ass* functions as the head of a Degree phrase. One motivation for this analysis comes from the idea that *ass* often intensifies the meaning of the modifier in the construction.⁴⁹ A sketch of this analysis is shown in (106), based on the idea that DegP is the functional projection that dominates the adjective phrase (Abney 1987).

(106)

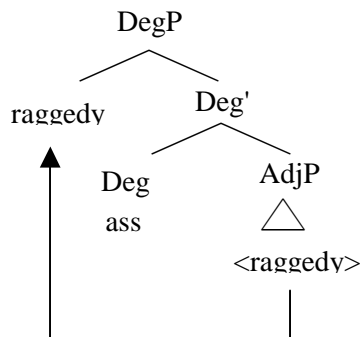

4.2.1 Advantages of the Degree word analysis

This analysis is appealing for several reasons. There is evidence that movement occurs in degree phrases (Matushansky 2002), and the movement shown in (106) gets the ordering right

(iii) That filthy yellow dog just bit me!

(iv) ? That yellow filthy dog just bit me!

The same holds for the AAC, with both being acceptable, but (v) being preferable.

(v) That filthy ass yellow ass dog just bit me!

(vi) ? That yellow ass filthy ass dog just bit me!

⁴⁸ Note that informants accepted all three forms: *fool ass boy*, *foolish ass boy*, *fool boy*.

⁴⁹ Though native speakers say that it does not do so in all cases, as I have noted (cf. Spears 1998, 236).

with respect to *ass* and *raggedy*. It also captures the intuition that *ass* is semi-functional in nature when used in the AAC (as well as the ACC), as evidenced by the fact that the word appears “semantically bleached,” to use Spears’s description (Spears 1998, 236). It is also the case that degree words can have an unusual distribution, sometimes occurring before, and sometimes after the adjectives that they modify (cf. Bresnan 1973, Neeleman, Koot & Doetjes 2004). The word *ass*, then, might pattern something like the mainstream English word *enough*, which can follow its adjective (107) (see Kayne 2005b, 149ff.).⁵¹

(107) Jamie is crazy enough.

Further work needs to be done on the extent to which the a-word in the AAC patterns like degree words. One interesting observation that emerged from preliminary informant work in this area is that the AAC is only sometimes acceptable with numerals. The pattern in (108) suggests that the a-word cannot attach to numerals.

(108) a. He wears three ties every week.
b. *He wears three ass ties every week.

This data makes it seem like the a-word functions as a degree word, since degree words cannot generally modify numerals (since they are not gradable), as we see in (109) (mainstream English, my own judgments).

(109) a. Those three ties are ugly.
b. *Those very three ties are ugly.
c. *Those incredibly three ties are ugly.

On the other hand, informants judged the following use of numerals in the AAC as acceptable.

(110) a. He wears the same three ass ties every week!
b. They pay me just seven ass dollars for all that work!

I leave further exploration of these interesting patterns for future research.

4.2.2 Weaknesses of the Degree word analysis

Perhaps the biggest weakness of this analysis as I have sketched it here is that it incorrectly predicts that predicates uses of the AAC are acceptable. This is shown in (111)-(112).

(111) a. *Your teeth are big ass.
b. You got some big ass teeth.
(112) a. *Those sweaters are raggedy ass.
b. Those are some raggedy ass sweaters.

⁵⁰ Although many analyses take degree words to be functional, it may be that they do not form a closed class, as evidenced by what I take to be the newish word *mad* in colloquial AAE:

- (i) There are *mad* Haitians in Queens. (unelicited)
(ii) It's *mad* hot today. (<http://www.urbandictionary.com/define.php?term=mad>)

⁵¹ Another parallel with *enough* is seen the fact that it can directly modify nominals, unlike other degree words, as in (i) (versus (ii)):

- (iii) He's man enough to do that.
(iv) *He's too man to do that.

We need not discard the degree analysis completely, though, because it may provide one piece of the puzzle. I have shown above that there are strong reasons to reject an analysis in which the a-word constituent (e.g., *raggedy ass*) is a DP. But what category is this constituent projected from? One possibility is that the modifier is hijacked into a DegP headed by *ass*. Note that the modifier cannot start out the derivation as the complement of a DegP headed by *ass*, because this would predict that (111)a and (112)a are acceptable. But it makes sense that the modifier ends up in such a constituent for the reasons that I have discussed above, though I leave the details of this part of the analysis open for future research.

4.3 Hijacking, or Focus?

Although I have argued that an analysis involving predicate raising interrupted by sideward movement and followed by interarboreal movement (80) is the right one for the AAC, it is worth considering an alternative analysis that does not involve certain of these operations. In particular, theorists have argued that sideward movement, since it is not constrained by c-command, has the drawback of overgeneration (see Bobaljik & Brown 1997, Nunes 2001 for some discussion); and the analysis I have adopted here does not constrain sideward movement with c-command (like Collins 2007, but contra Bobaljik & Brown 1997 and Nunes 2001). In this section I will sketch a derivation of the AAC that does not involve sideward or interarboreal movement. I will show this derivation with *a raggedy ass sweater* (75), as above.

This alternative analysis will draw on recent applications of Rizzi's (1997) expanded left periphery of the CP. If expanding the left periphery of the CP into projections like Force, Topic, Focus, and Finite is on the right track, then the CP of relative clauses must also have this more finely articulated structure. In the following derivation, I analyze the a-word as a Focus head within the left periphery of the DP that contains the relative clause.

The derivation starts much like the one in (80). There is an initial predication relationship between the NP *sweater* and the a-word associate *raggedy*. The NP *sweater* raises to Spec-IP as usual, but the next step in the derivation is the external merge of the Focus head *ass*. This is shown in (113).

(113)

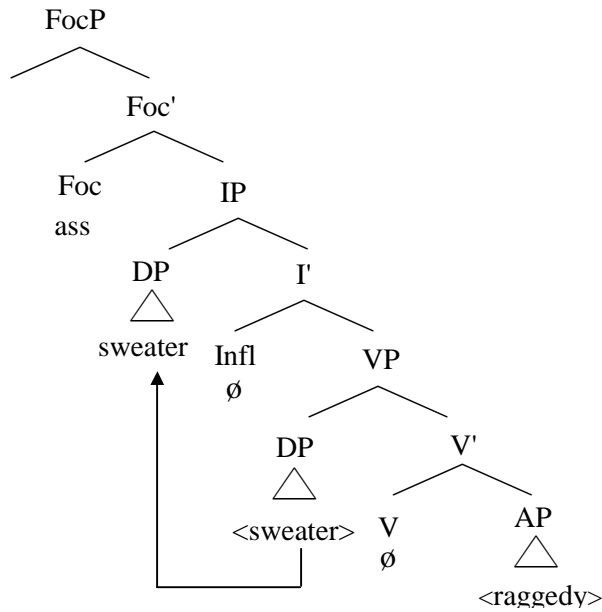

Next, predicate raising happens as usual. Note that what was CP in (80) is now expanded into Force, Topic, Focus, and Finite in (113). The raised predicate now goes to Spec-ForceP (since Force⁰ is analyzed as being similar to C⁰).⁵² The last step of the derivation is the merger of the D⁰ head. The complete derivation is shown in (114).

⁵² A variant of this derivation might be for movement of the predicate to be to Spec-FocusP, with the Focus-word *ass* triggering the movement of the predicate to its specifier. This derivation would provide a good motivation for the movement of the predicate, but it would violate Collins's (2007a) version of the "doubly filled Comp filter," in which either the head or the specifier of a projection can be overtly pronounced, but not both (Collins 2007, 3).

(114)

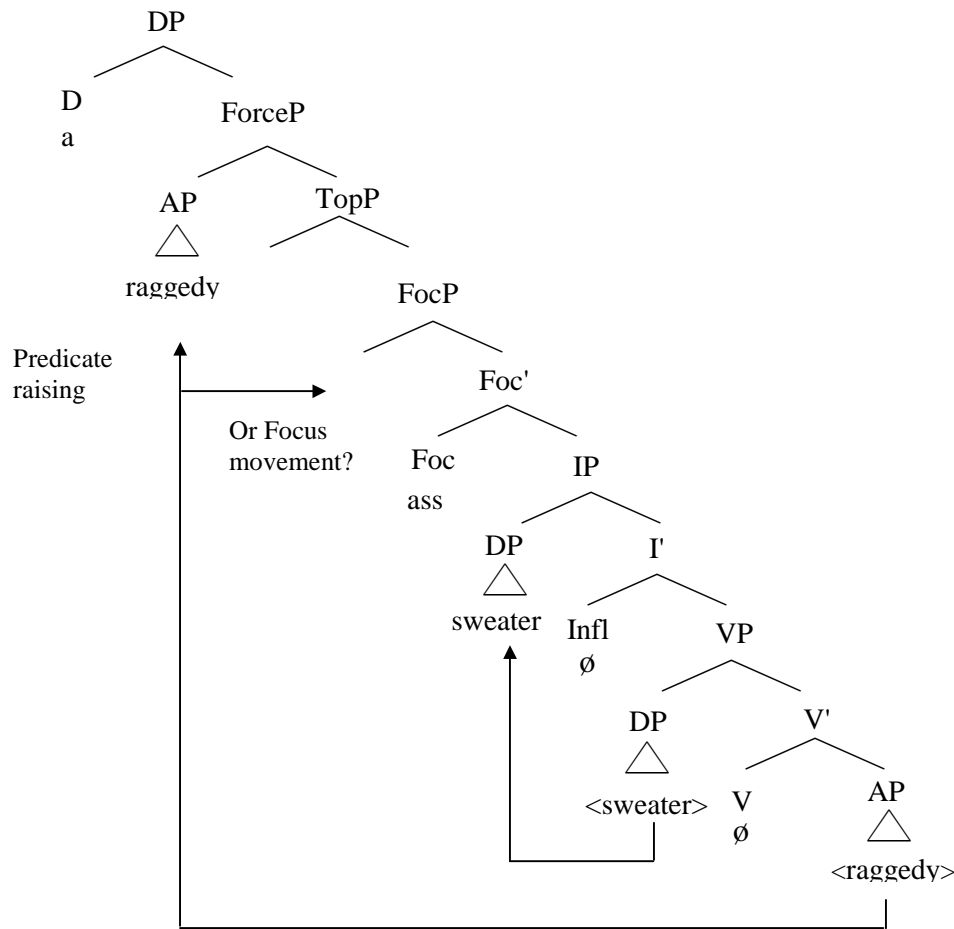

4.3.1 Discussion

The derivation in (114) has the advantage of showing why the a-word associate always occurs before the a-word. In (114), for example, *raggedy* moves to either Spec-ForceP (or Spec-FocP). The derivation in (114) thus gets this simple word order fact about the AAC right. It also captures the intuition that the a-word serves to emphasize the predicate. Although Spears (1998) and my informants reject the claim that the AAC *always* serves to emphasize the predicate, it could still be the case that non-emphatic uses of the AAC have this same structure.

This derivation also has at least one more advantage. It could provide a neat explanation for the microparametric difference between AAE and mainstream varieties of English: in AAE, the Foc⁰ can be overtly pronounced; in mainstream English, Foc⁰ cannot be overtly pronounced. We can also then say that AAE has more than one lexical item that is subcategorized for Foc⁰, since we have seen that both *ass* and *behind* are available in the AAC.

Does this analysis explain the fact that the AAC cannot, in general, serve as a predicate? I argued above that the AAC facts support the idea that predicative adjectives have a different derivation from attributive adjectives, and that predicate raising happens only with attributive

adjectives. The AAC is always attributive because it is, in a sense, parasitic on predicate raising. Hijacking into the a-word constituent is possible only if predicate raising is possible. The analysis involving Focus in (114) does not capture this dependency of the AAC on predicate raising, and thus does not quite explain the attributivity of the AAC. In (114), the availability of the AAC depends solely on whether or not a lexical item is merged into Foc^0 .

In addition, the analysis in (114) has another weakness, one that I argue makes it inferior to the hijacking analysis. This derivation does not show a connection between the AAC and the ACC (“*ass* camouflage construction”), as CMP have analyzed it. As I discuss in section 1.3, CMP show that a camouflage analysis must be the right one for the ACC in order to explain the complex behavior involving subject-verb agreement and the binding of reflexives with the ACC. When speaking in what Spears (1998, 232) calls “uncensored mode,” speakers move easily between AAC and ACC constructions, as I showed in (105), repeated below as (115) (Steve Harvey, Lee 2000, italics added).

- (115) a. How y’all doin with y’all *country ass*?
 b. You know *your ass is country!* Don’t be looking around!
 c. I’m country my damn self, that’s how I know *country ass people* when I see ‘em.

Examples (115)a and (115)b are CMP’s ACC, and (115)c is the AAC. As I have noted, it would be very surprising if there were no structural similarity between these two constructions. Further evidence that the structures are related comes from my informant work. One informant rejected sentence (116)a (using the [+human] AAC) and said that he would say (116)b (using the ACC) instead.

- (116) a. *Madonna is a famous ass. (AAC)
 b. Madonna’s ass is famous. (ACC)

I would argue that this is one more bit of evidence showing that these structures have to be transformationally related.

5 Unpronounced PERSON in the AAC

5.1 Introduction

In this section I argue for the presence of an unpronounced PERSON morpheme in one use of the AAC. In particular, I will argue that sentences like those in (117) should be analyzed as shown in (118).

- (117) a. Gwen’s brother is a stupid ass.
 b. That kid is a punk ass.
 c. Some crazy ass must have done that.
 d. Look where that fool ass parked.
- (118) a. Gwen’s brother is a stupid ass PERSON.
 b. That kid is a punk ass PERSON.
 c. Some crazy ass PERSON must have done that.

- d. Look where that fool ass PERSON parked.

The idea that a nominal may be unpronounced but syntactically relevant is not a new one, and arguments have been made for such elements in many different languages, going back at least to (Katz & Postal 1964). More recently, Kayne (2005a, 2005b, 2005c) argues that constructions in English like *at the age of seven* contain the unpronounced noun *YEARS*. Other work reveals cross-linguistic evidence for the unpronounced nominal PERSON in languages such as Dutch and English (Kester 1996), non-standard dialects of Dutch (Corver 2008), and Italian (Rizzi 1986a, Cattaneo 2007).

One obvious characteristic shared by all analyses involving an unpronounced PERSON is that this silent morpheme is nominal and carries the feature [+human]. Particularly relevant to the AAC is Kester's (1996) analysis of what she calls the "null noun *pro*" in adjectival contexts (Kester 1996, 57). Kester argues that sentences like (119)a involve this kind of *pro*. Kester thus analyzes (119)a as (119)b and calls it the "human" construction (Kester 1996, 60).

- (119) a. The rich are taking over.
 b. The rich *pro* are taking over.

In other words, although some might analyze the sentence in (119) as involving a syntactic or morphological process of nominalization, Kester argues that the word *rich* actually remains adjectival in this context and actually serves to modify an unpronounced noun. I will make a similar argument for the [+human] AAC, for which I argue that the relevant adjective does *not* modify the a-word but modifies an unpronounced PERSON.⁵³

5.2 Evidence for PERSON in the [+human] AAC

5.2.1 Syntactic arguments

At first glance, one might analyze the bracketed constituents in (117) (repeated below as (120)) as involving a DP containing an NP with the head noun *ass*.

- (120) a. Gwen's brother is [a stupid ass].
 b. That kid is [a punk ass].

The tree in (121) shows what the analysis of the predicate [stupid ass] would look like, given my assumption that attributive adjectives originate from a relative clause source. Note that I will argue that (121) does *not* show the right analysis for the [+human] AAC as in (120)a.

⁵³ It should be noted that Kester talks about *pro*, not PERSON. I do not know of any work that discusses the differences between *pro* and PERSON; a topic for further research, then, is the question of whether *pro* or PERSON is involved in the AAC, as well as sentences involving "the human construction" (e.g., *the rich*). The analysis I give here assumes that the relevant unpronounced material is PERSON and not *pro*, but further work needs to be done in this area.

(121)

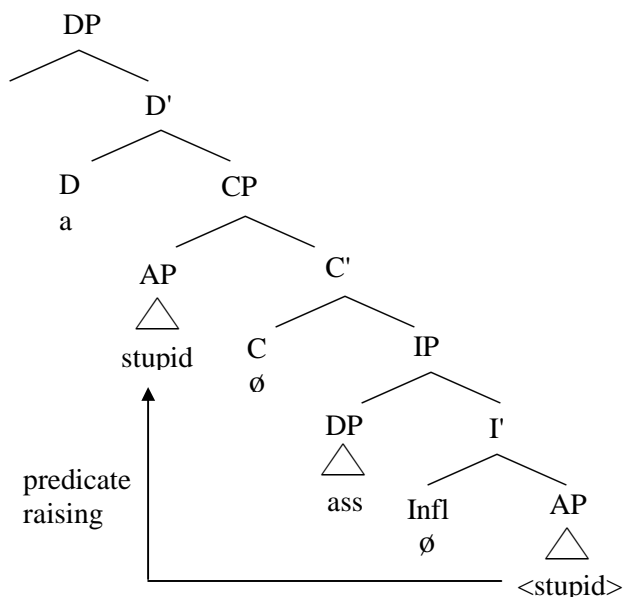

I will argue that the a-word does not and cannot function as a head nominal in the AAC, but that an unpronounced PERSON morpheme does function as the head nominal. In addition, the modifier in the [+human] AAC is—while on its predicate-raising way—hijacked into a camouflage constituent, just as it is in the canonical AAC. The [+human] AAC is therefore just a special case of the canonical AAC: the only difference is that the head noun in the [+human] AAC is PERSON (122).

(122)

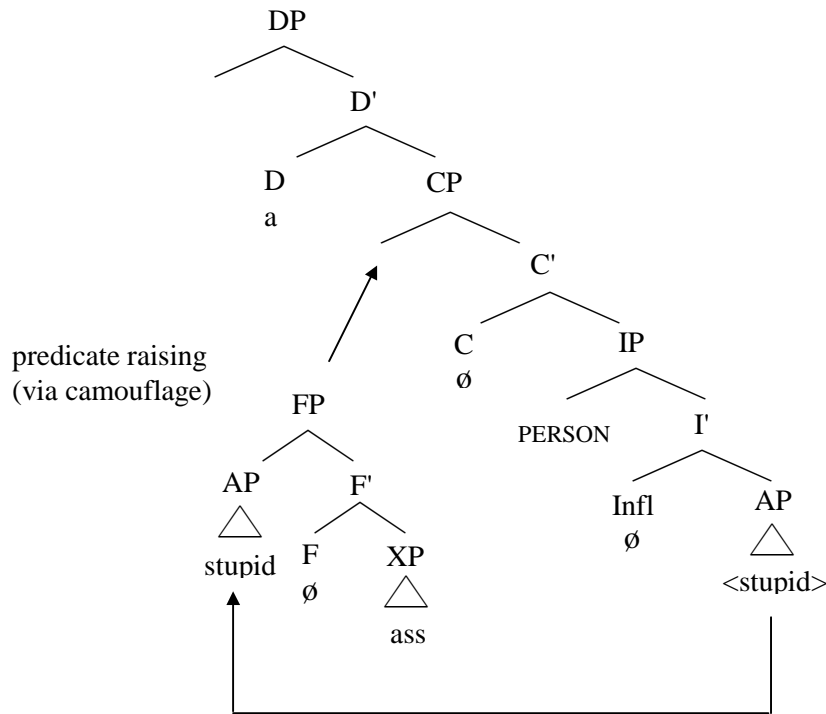

Several syntactic arguments show that the a-word in the AAC is not fully nominal. Recall that the a-word in the AAC cannot be a possessor. Examples (49), repeated below as (124), shows that the a-word in the canonical AAC cannot be a possessor; example (50), repeated as (125), shows that the unpronounced PERSON in the [+human] construction cannot be a possessor.

- (123) a. *Jamie’s ugly ass’s car is broken.
- b. Jamie’s ugly ass car is broken.

- (124) a. *Some stupid ass’s car is parked in my spot.
- b. Some stupid ass is parked in my spot.

And as noted in (52), repeated in part as (125), the a-word cannot be made plural in the canonical AAC.⁵⁴

- (125) a. *There are some crazy asses people who live on my street.
- b. *You should throw away them ugly asses clothes.

Similarly, in most cases the a-word in the [+human] AAC cannot be made plural, though informants judgments were split on (127)a.

- (126) a. %Your friends are a bunch of crazy asses.
- b. *Your friends are a bunch of crazy ass.

⁵⁴ As I pointed out in footnote 31, this is not all that surprising, since we see no inflection in phrases like *a two bedroom(*s) apartment*.

- c. You have a bunch of crazy ass friends.
- (127) a. *Some punk asses must have done that.
- b. Some punk ass kids must have done that.

The data in (126)-(127) make sense, given that the [+human] AAC is just a special case of the canonical AAC. Furthermore, it suggests that PERSON here functions more purely as a light noun in not allowing for plural inflection (Collins 2007, Leu 2005, Kishimoto 2000; cf. Kayne 2005c, 252ff.).

There is further reason to think that the a-word in the [+human] AAC is not the head nominal in sentences like (120), but that the a-word associate actually modifies an unpronounced PERSON. The a-word does not appear to be fully nominal. For example, although (128) is acceptable with the substitution of *one* for *doctor*, the same substitution cannot be done with (129).⁵⁵

- (128) My cousin is a lousy doctor, and my brother is a lousy one too.
- (129) *[?]My younger brother is a stupid ass, and my older brother is a stupid one too.

5.2.1.1 Some exceptions

I noted above that informants had split judgments for (127)a, with a plural a-word in the [+human] AAC. In other words, this speaker judged (130) to be acceptable.

- (130) Your friends are a bunch of crazy asses.

Why would this be? Could it be that the a-word is being inflected? I would argue that even in (130), the a-word remains uninflected. It may be, however, that some speakers allow unpronounced nominal PERSON in the [+human] construction to host a plural morpheme. In this case, the structure of *some crazy asses* would be sketched as below in (131), assuming that the plural morpheme is generated as part of the PERSON constituent.

- (131) [some [[~~PERSON-s~~ crazy] ass] PERSON-s]

The important thing to note about (131) is that it results in an apparent mismatch between pronunciation and constituent structure; although it sounds like the plural morpheme is attached to *ass* when the sentence is spoken, in reality this plural marker forms a constituent with unpronounced PERSON.⁵⁶ Interestingly, this same speaker also accepted *one* resumption in (129). From these judgments, it appears that this speaker has a less restrictive grammar for unpronounced PERSON. More informant work must be done to see how much variation exists along these lines with respect to unpronounced PERSON, both in the AAC and throughout the grammar.

⁵⁵ There might be a problem with this test, since for me, (i) is bad:

(i) *My older brother is a stupid jerk and my younger brother is a stupid one too.

Perhaps a better paradigm would be the following (AAE judgments from informants):

(ii) *Jamie's brother is a stupid ass, and he's a lazy one too.

(iii) Jamie's brother is a stupid jerk, and he's a lazy one too.

⁵⁶ This pattern is like the one Kayne (2005c, 256ff.) describes for (iv) in which the plural marker appears to be on the adjective, but which Kayne argues is on the silent noun.

(vii) two seven-year-old CHILD s (Kayne 2005c, 256, example 110)

5.2.2 *Semantic arguments*

The semantic arguments for the presence of unpronounced PERSON in the AAC come from the fact that the a-word does not carry a full set of semantic features. The a-word is non-referential, and it does not carry connotations associated with *ass* when this word is used as an epithet, perhaps short for *asshole*.⁵⁷ CMP point out that in the ACC, the truth conditions are different between constructions with and without stress on the a-word. The same is true in the [+human] AAC. In the AAC, stress is always on the adjective or noun that goes with the a-word. Putting stress on the a-word changes truth conditions, as previously noted for the sentences in (65), repeated below as (132).

- (132) a. Jamie's brother is a STUPID ass. [+human] AAC
 b. Jamie's brother is a stupid ASS. not an AAC construction

Recall that (132)a does not entail that Jamie's brother is an unpleasant person, but (132)b does.

One of the most important semantic arguments for the presence of unpronounced PERSON in the predicative AAC is the fact that this construction is limited to [+human] contexts. In other words, although (133)a is acceptable, (133)b-c are not.

- (133) a. Jamie's brother is a lazy ass.
 b. *Jamie's cat is a lazy ass.
 c. *Jamie's coat is a raggedy ass.

Note that analogous examples for "the human construction" in mainstream English, would be the following.

- (134) a. *The furry stay warm through the winter.
 b. The furry animals stay warm through the winter.

5.3 Unpronounced PERSON and indefinite pronouns

Recall that although many of the examples above involve a copular sentence with a predicate (such as *a crazy ass*), which I argue involve unpronounced PERSON, it is also the case that the [+human] construction can appear in other syntactic positions, as shown (36), repeated as (135).⁵⁸

- (135) a. Some crazy ass must have done that.
 b. Look where that fool ass parked.

Moreover, we are now in a position to understand more fully data like that in (136).

- (136) a. Some crazy ass kid must have done that.
 b. Someone crazy must have done that.
 c. *Someone crazy ass must have done that.

⁵⁷ Although I have noted above that the AAC can be used to express positive evaluation, it should be noted that none of the examples of the [+human] AAC that I have found involved positive evaluation. However, if my analysis of the [+human] AAC as a subset of the canonical ACC is on track, then further informant work should reveal such examples.

⁵⁸ This section owes much to Leu (2005).

Sentence (136)c is unacceptable because in order to get the AAC, the predicate has to undergo raising. If we assume a *reduced* relative clause analysis for (136)b, an analysis in which the predicate does not undergo raising, then it makes sense that (136)c is ungrammatical. But what about data like that in (137)?

- (137) a. Some crazy ass must have done that.
 b. Some stupid ass left the door open.

These sentences must involve unpronounced PERSON. In other words, I analyze the sentences in (137) as shown in (138).

- (138) a. Some crazy ass PERSON must have made that mess.
 b. Some stupid ass PERSON left the door open.

These sentences involve movement into a camouflage constituent and predicate raising just as we have seen in the canonical AAC; the only difference here is that the nominal in the reduced relative clause is unpronounced PERSON. It is worth noting that the only kind of unpronounced nominal in the reduced relative clause is a [+human] one. In other words, the following are ungrammatical (139).

- (139) a. *Some stupid ass is barking. (referring to a dog)
 b. *That raggedy ass should be thrown away. (referring to a sweater)

5.4 Asymmetries between the canonical and the [+human] AAC

This section discusses some tricky asymmetries between the canonical AAC and the [+human] AAC, and I do not have satisfying analyses for all of them. But because the data here is important for a complete understanding of the AAC, I will describe it and offer some tentative analyses for why we see the patterns that we do.

Recall that not all modifiers (a-word associates) are acceptable in the [+human] AAC. Although my speakers accept some of the data that Spears (1998) rejects, there are still others they do reject. The examples in (140)-(141) show how in some cases, an a-word associate that is acceptable in the canonical AAC (the (a) examples) cannot occur in the [+human] AAC (the (b) examples). Note that examples (140)b-(141)b are unacceptable with the stress pattern of the AAC, in which *ass* does not carry stress (cf. section 2.6.4).

- (140) a. He is a sorry ass man.
 b. *He is a sorry ass.
 (141) a. That guy is Gwen's old ass boyfriend. (*old* = ex-)
 b. *That guy is an old ass. (where *old* = ex- or *old* = old in age)

These patterns might be explained by the fact that the adjectives in question (*sorry*, *old*) cannot occur in a non-attributive position (142).

- (142) a. *That man is sorry.
 b. *That guy is old. (*old* = ex-)

It may be that adjectives such as these are not first merged into the exact same kind of predicational structure that I have been assuming for the AAC so far.

On the other hand, the first-merge position of modifiers like *sorry* cannot be the whole story, because an adjective like *famous* is perfectly acceptable in non-attributive position, as shown in (143), but is not acceptable in the [+human] AAC (and in the canonical AAC), as shown in (144).

- (143) Madonna is famous.
 (144) a. Madonna is a famous ass musician.
 b. *Madonna is a famous ass.⁵⁹

It is surely not the case that the word *famous* does not normally modify [+human] nominals; that cannot be the reason for its unavailability in the AAC [+human] construction. No doubt there are more examples of this type. Further work remains to be done on what structural and lexical-semantic properties result in these asymmetries.

In section 2.2, I noted two apparent exceptions to the attributivity of the AAC (examples (15)-(16)). The data are repeated below as (145)-(146).

- (145) a. Hey, I'm a grown ass man!
 b. *Hey, I'm a grown ass!
 c. Hey, I'm grown ass!
 (146) a. He's a broke ass man.
 b. *He's a broke ass.
 c. He's broke ass.

Although speakers' judgments were not all the same for (145)c and (146)c (for one speaker, (145)c and (146)c were ungrammatical), if it turns out that a larger poll of speakers find them to be grammatical, then these examples appear to violate the AAC as I have described it, since I have argued that the AAC cannot be used as a predicate.

One explanation for why (145)b and (146)b are ungrammatical might come from argument structure and the fact that both *broke* and *grown* are derived from verbs; furthermore, these verbs are unaccusative. It may be that AAC constructions that are derived from past participle predicates like *broke* and *grown* have a slightly different derivation from those in which the a-word associate is a noun or an adjective, and that this difference results in the unavailability of the [+human] construction. I will leave further explanation for future research.

But why would (145)c and (146)c, the examples in which the AAC appears to be predicative, be available to some speakers? Again, the answer might lie in the derivation of the AAC for deverbal a-word associates. It may be that with deverbal a-word associates, further movement takes place that renders unpronounceable the determiner that introduces the relative clause. A sketch of this explanation is shown in (147).

⁵⁹ One informant reports that he would have to use a camouflage construction (ACC) to convey (144)b:

(i) Madonna's ass is famous.

This example gives further evidence that there must be structural similarities between the ACC and the AAC.

(147)

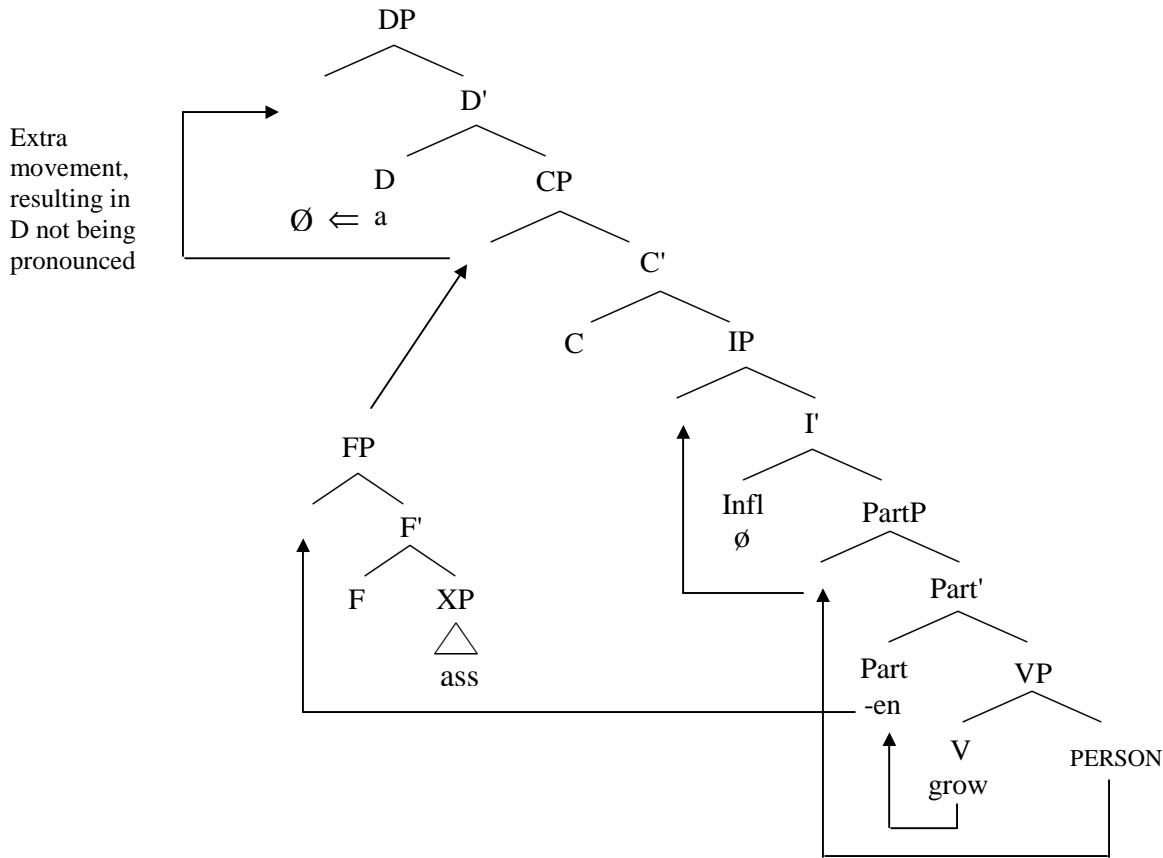

6 Conclusion

This paper has shown that a particular construction in AAE, the AAC, gives support for the predicate raising analysis of attributive adjectives and evidence of syntactically relevant unpronounced nominals, in this case, unpronounced PERSON. My analysis of the AAC makes use of a combination of predicate raising and sideways movement, and because the possibility of sideways movement relies on the availability of predicate raising, I have called this type of movement *hijacking*—in this case, hijacking into a camouflage constituent. It remains to be seen whether other syntactic phenomena are best analyzed in terms of hijacking.

I have described the AAC as a syntactic construction made available by the grammar of AAE, but I have not discussed in a broader way what parametric differences might result in availability of this form in AAE (and other dialects of English that have the AAC) and the unavailability of this form in other dialects of English. I leave this for future research, but my sense is that the difference may lie in the features of a-words. In particular, the a-words appear to belong to a functional-like category that I have suggested was a DegP but that might turn out to be category-neutral heads. More syntactic work on AAE will reveal the broader connections between the features and mechanisms that underlie the AAC and other more general syntactic phenomena in the grammar of AAE.

References

- Abney, Steven Paul. 1987. The English Noun Phrase in its Sentential Aspects. Ph.D. dissertation, MIT, Cambridge, MA.
- Aboh, Enoch. 2004. Topic and focus within D. *Linguistics in the Netherlands*, 21: 1–12.
- Alexiadou, Artemis. 2001. Adjective Syntax and Noun Raising: Word Order Asymmetries in the DP as the Result of Adjective Distribution. *Studia Linguistica* 55: 217-248.
- Baker, Mark C. 2003. *Lexical Categories: Verbs, Nouns, and Adjectives*. Cambridge, New York: Cambridge University Press.
- Barker, Chris. 2005. Vagueness (article 1083). In *Encyclopedia of Language and Linguistics*, 2nd ed. Ed. by Brown, Keith. Oxford, UK: Elsevier.
- Bernstein, Judy B. 2001. The DP Hypothesis: Identifying Clausal Properties in the Nominal Domain. In *The Handbook of Contemporary Syntactic Theory*, eds. Baltin, Mark R., and Chris Collins, 536-561. Malden, MA: Blackwell.
- Bernstein, Judy. 1993. The Syntactic Role of Word Markers in Null Nominal Constructions. *Probus* 5: 5-38.
- Bobaljik, Jonathan David, and Samuel Brown. 1997. Interarboreal Operations: Head Movement and the Extension Requirement. *Linguistic Inquiry*, 28: 345-356.
- Bolinger, Dwight. 1967. Adjectives in English: Attribution and Predication. *Lingua* 18: 1-34.
- Bresnan, Joan. 1973. Syntax of the comparative clause construction in English. *Linguistic Inquiry* 4: 275-343.
- Carr, Steve (director). 2000. *Next Friday* [DVD]. New Line Cinema.
- Cattaneo, Andrea. 2007. Italian Null Objects, Resultative/Depictive Predication, and HAB. *NYU Working Papers in Linguistics* 1.
- Chomsky, Noam. 1993. A minimalist program for linguistic theory. In *The view from Building 20: Essays in linguistics in honor of Sylvain Bromberger*. Ed. by Kenneth Hale and Samuel Jay Keyser, 1-52. Cambridge, MA: MIT Press.
- Chomsky, Noam. 1995. Categories and transformations. In *The Minimalist Program*, 219–394. Cambridge, Mass.: MIT Press
- Cinque, Guglielmo. 2005 ms. The Dual Source of Adjectives and Phrasal Movement in the Romance DP.
- Cinque, Guglielmo. 1994. On the Evidence for Partial N-Movement in the Romance DP. In *Paths Towards Universal Grammar: Studies in Honor of Richard S. Kayne*, eds. Cinque, G., et al., 85-110. Washington, DC: Georgetown University Press.
- Collins, Chris. 2007a. An AAE Camouflage Construction. Paper presented at the Department of Linguistics, University of Maryland.
- Collins, Chris. 2007b. Home Sweet Home. *NYU Working Papers in Linguistics*, 1.
- Collins, Chris, Simanique Moody, and Paul Postal. 2008. An AAE Camouflage Construction. *Language* 84: 29-68.
- Corver, Norbert. 2008 ms. On Silent Semi-Lexical *Person*. Unpublished manuscript.
- Den Dikken, Marcel. 2006. *Relators and Linkers: The Syntax of Predication, Predicate Inversion, and Copulas*. Cambridge, MA.: MIT Press.
- Gray, F. Gary (director) & Ice Cube (producer). 1995. *Friday* [DVD]. United States: New Line Home Video.
- Green, Lisa J. 2002. *African American English: A Linguistic Introduction*. Cambridge, New York: Cambridge University Press.

- Kamp, Hans, and Barbara Partee. 1995. Prototype Theory and Compositionality. *Cognition*, 57: 129-191.
- Katz, Jerrold J., and Paul Martin Postal. 1964. *An Integrated Theory of Linguistic Descriptions*. Cambridge, MA: MIT Press.
- Kayne, Richard S. 2005a. A Note on the Syntax of Quantity in English. In *Movement and Silence*, ed. Kayne, Richard S., 176-214. Oxford: Oxford University Press.
- Kayne, Richard S. 2005b. On Some Prepositions that Look DP-Internal. In *Movement and Silence*, ed. Kayne, Richard S., 136-175. Oxford: Oxford University Press.
- Kayne, Richard S. 2005c. Silent Years, Silent Hours. In *Movement and Silence*, ed. Kayne, Richard S., 241-260. Oxford: Oxford University Press.
- Kayne, Richard S. 1994. *The Antisymmetry of Syntax*. Cambridge, MA: MIT Press.
- Kester, Ellen-Petra. 1996. Adjectival Inflection and the Licensing of Empty Categories in DP. *Journal of Linguistics* 32: 57-78.
- Laenzlinger, Christopher. 2005. French Adjective Ordering: Perspectives on DP-Internal Movement Types. *Lingua* 115: 645-689.
- Larson, Richard K., and Franc Marušič. 2004. On Indefinite Pronoun Structures with APs: Reply to Kishimoto. *Linguistic Inquiry* 35: 268-287.
- Lee, Spike (producer and director). 2000. *The Original Kings of Comedy* [DVD]. United States: Paramount Home Video.
- Leu, Thomas. 2009. From Greek to Germanic: Poly-(*in)-Definiteness and Weak/Strong Adjectival Inflection. In *Merging Features*, ed. by José M. Brucart, José M., Gavarró, Anna, and Jaume Solà. Oxford, UK: Oxford University Press.
- Leu, Thomas. 2005. Something Invisible in English. *UPenn Working Papers in Linguistics 11, Proceedings of PLC 28*: 143-155.
- Matushansky, Ora. 2002. Movement of Degree/Degree of Movement. Ph.D. dissertation, MIT, Cambridge, MA.
- Mufwene, Salikoko S. 1998. The Structure of the Noun Phrase in African-American Vernacular English. In *African-American English: Structure, History and use*, eds. Mufwene, Salikoko S., et al., 69-81. London: Routledge.
- Neeleman, Ad, J. van de Koot, and J. Doetjes. 2004. Degree expressions. *The Linguistic Review* 21: 1-66.
- Nunes, J. 1995. The Copy Theory of Movement and Linearization of Chains in the Minimalist Program. Ph.D. dissertation, University of Maryland, College Park, MD.
- Nunes, Jairo. 2001. Sideward Movement. *Linguistic Inquiry* 32: 303-344.
- Rizzi, Luigi. 1986a. Null Objects in Italian and the Theory of *Pro*. *Linguistic Inquiry* 17: 501-557.
- Rizzi, Luigi. 1986b. On chain formation. In *Syntax and semantics 19: The syntax of pronominal clitics*. Ed. by Hagit Borer, 65-95. Orlando, FL: Academic Press.
- Rizzi, Luigi. 1997. "The Fine Structure of the Left Periphery." Ed. by Liliane Haegeman, *Elements of Grammar*, 281-337. Dordrecht: Kluwer.
- Roehrs, Dorian. 2007. Split-NPs as an Instance of Sideward Movement. *University of Pennsylvania Working Papers in Linguistics*, 13: 323-336.
- Smith, Carlota S. 1961. A Class of Complex Modifiers in English. *Language*, 37: 342-365.
- Smitherman, Geneva. 1994, 2000. *Black Talk: Words and Phrases from the Hood to the Amen Corner*. Boston: Houghton Mifflin.

- Spears, Arthur. 1998. African-American Language Use: Ideology and So-Called Obscenity. In *African-American English: Structure, History, and use*, eds. Mufwene, Salikoko S., et al., 226-250. London: Routledge.
- Sproat, Richard, and Chilin Shih. 1990. Cross-Linguistic Distribution of Adjective Ordering Restrictions. In *Interdisciplinary Approaches to Language: Essays in Honor of S.-Y. Kuroda*, eds. Georgopoulos, C., and R. Ishihara. , 565-593. Dordrecht: Kluwer Academic Publishers.
- Sproat, Richard, and Chilin Shih. 1988. Prenominal Adjective Ordering in English and Mandarin. *NELS* 18: 465-489.
- Svenonius, Peter. 2008. The Position of Adjectives and Other Phrasal Modifiers in the Decomposition of DP. In *Adjectives and Adverbs: Syntax, Semantics, and Discourse*, ed. McNally, Louise and Kennedy, Chris, Oxford UK: Oxford University Press.
- Valois, Daniel. 2006. Adjectives: Order within DP and Attributive APs. In *The Blackwell Companion to Syntax*, eds. Everaert, Martin, and Henk C. van Riemsdijk